



PREMIER®



OWNER'S MANUAL
2027





Congratulations on the purchase of your new pontoon from Premier Marine.

We have taken great care and pride in the design and construction of your new boat so that you may enjoy it for many years to come. Please read thoroughly all materials enclosed within your Owner's Packet. We hope you will find the guidelines and suggestions useful.

Please take the time to verify your warranty registration on your new boat by contacting your dealer.

Premier Marine, along with our entire dealership network, is here to provide service to you. We are dedicated to our product and our customers. If at any time you have questions or comments about your boat, first contact the dealership where you purchased your boat. If you need additional service, please feel free to contact Premier.

We at Premier value you, your family and friends. Always practice safe boating while operating your Premier boat. Do not operate your boat under the influence of alcohol or drugs and always wear your life jackets.

Happy boating!

Premier Marine, LLC

This manual has been compiled to help you operate your pontoon with safety and pleasure. It contains details of the craft, the equipment supplied or fitted, its systems, and information on its operation and maintenance. Please read it carefully and familiarize yourself with the pontoon before use.

If this is your first boat, or if you are changing to a type of craft you are not familiar with, for your own comfort and safety, please ensure that you obtain handling and operating experience before assuming command of the pontoon. Your dealer or yacht club will be pleased to advise you of local sea schools or competent instructors.

PLEASE KEEP THIS MANUAL IN A SECURE PLACE, AND HAND IT OVER TO THE
NEW OWNER WHEN YOU SELL THE CRAFT.

Premier Marine is a member of NMMA (National Marine Manufacturers Association) which certifies the production of boats to comply to the recommended practices and engineering standards of the American Boat and Yacht Council and the U.S. Coast Guard. These standards apply to all Premier boats.

Because of our policy of continuous product improvement, the illustrations used in this manual may not be the same as your boat and are intended as representative reference views. Some controls, indicators or information may be optional and not included on your boat.



TABLE OF CONTENTS

1 INTRODUCTION	1.1	5 UNDERWAY	5.1
Design Features.....	1.2	Boater's Checklist.....	5.1
Safety/Hazard Communication Statements	1.2	Fueling.....	5.1
Owner Advisory Statements.....	1.2	Loading Passengers and Gear	5.2
Protecting the Environment.....	1.2	Starting the Engine	5.3
General Information.....	1.3	Leaving the Dock.....	5.3
Boat Delivery Responsibilities	1.3	Steering.....	5.4
Safety/Hazard Labels	1.4 - 1.5	Boat Speed.....	5.4
Warranty.....	1.6	Accelerating.....	5.4
Transfer of Warranty	1.6	Trimming.....	5.4
Equipment Manufacturer Manuals	1.6	General Rules of Seamanship	5.5
Owner Responsibilities	1.6	Stopping.....	5.5
Boating Laws and Regulations	1.6	Anchoring.....	5.5
Command Anchor Best Practices	1.7	Docking.....	5.6
Occupant Positions.....	1.7	Mooring.....	5.6
Occupant Positions by Model.....	1.8 - 1.10	Emergency Operation.....	5.6 - 5.7
2 SAFETY	2.1	Accident Reporting.....	5.8
Safe Boating Recommendations.....	2.1	6 CARING FOR YOUR BOAT	6.1
Safety Gear and Equipment	2.1	Engine.....	6.1
Personal Flotation Devices.....	2.1	Aluminum Surfaces	6.1
Fire Extinguisher	2.2	Plastic Component Maintenance	6.1
Sound Signaling Device.....	2.2	Tubes.....	6.1
Navigation Lights	2.2	Saltwater Use	6.1
Visual Distress Signal.....	2.2	Deck Hardware and Fittings	6.2
Recommended Additional Gear and Equipment	2.3	Seat Coverings and Vinyl.....	6.2
Safe Boating Practices.....	2.3	Canvas and Boat Cover	6.2
Safe Operation	2.3	Floor Coverings	6.2
Carbon Monoxide	2.4	Fiberglass and Composites.....	6.2
Lanyard Stop Switch	2.5	Tube Maintenance	6.2
Tower.....	2.5	7 WINTERIZATION AND STORAGE	7.1
Water Sports	2.6	Preparation for Storage.....	7.1
Passenger Safety Message.....	2.7	Supporting Your Boat During Storage	7.2
Water Sports Responsibility Code.....	2.7	Recommissioning After Storage	7.2
3 SYSTEMS AND COMPONENTS	3.1	8 HELPFUL INFORMATION	8.1
Electrical System	3.1	Boating Regulations.....	8.1
Instruments	3.2	Rules of Seamanship	8.1
Controls.....	3.2	Recommended Reading.....	8.2
Electronics	3.3	Contacts	8.3
Canvas.....	3.4	Navigational Aids	8.3
4 TRAILERING	4.1	Navigational Aids Chart	Inside Back Cover
Trailer	4.1	9 BOATING TERMINOLOGY	9.1-9.4
Hitch	4.1	10 SERVICE & MAINTENANCE LOG	10.1-10.2
Safety Chains.....	4.1		
Trailer Guidelines.....	4.2		
Backing a Trailer	4.2		
Launching Guidelines.....	4.2		
Loading Your Boat on the Trailer.....	4.3		
Aquatic Invasive Species.....	4.4		

1 INTRODUCTION

You have made an excellent choice by selecting a Premier Pontoon to enhance your leisure time. Premier is in the business of creating a dream for you, whether you're out for a day of waterskiing, just taking a relaxing cruise, or heading out early in the morning for a day of fishing. Your dream includes something more than just a fine boat. That's why we've tucked into our pontoons seasons of serenity, seasons of togetherness, and seasons of fun. We'll help you find many perfect days like those you've always dreamed about.

Please take the time to read this manual before you take your boat out for the first time. Also, read all literature supplied by the manufacturers of the various components and accessories used on your boat. In particular, you'll want to become familiar with operating your engine.

If you are a novice boater, you may not be familiar with the terms experienced boaters use. Figure 1-1 will help you. It lists some common terms and how they apply to a typical boat.

Before your first boating excursion, look your boat over and become familiar with it. Find its components, gauges and operating equipment, and learn how to use them. Your outing will be safer and more enjoyable.

If a family member or friend operates your boat, be sure he or she fully understands the controls and operation of the boat. Each boat operator is responsible for ensuring the safety of the boat's passengers and other water users. Passengers should also be aware that courteous, responsible riding is important.

This manual is part of your boat's equipment. It does not supersede or change any of the original manufacturers' specifications, operation or maintenance instructions. Always keep it on board. If you transfer ownership of this boat to someone else, be sure to give this manual to the new owner and have them contact their Premier dealer to transfer warranty (see 1.6).

This manual is also available at www.pontoons.com/owners or scan the QR code below.

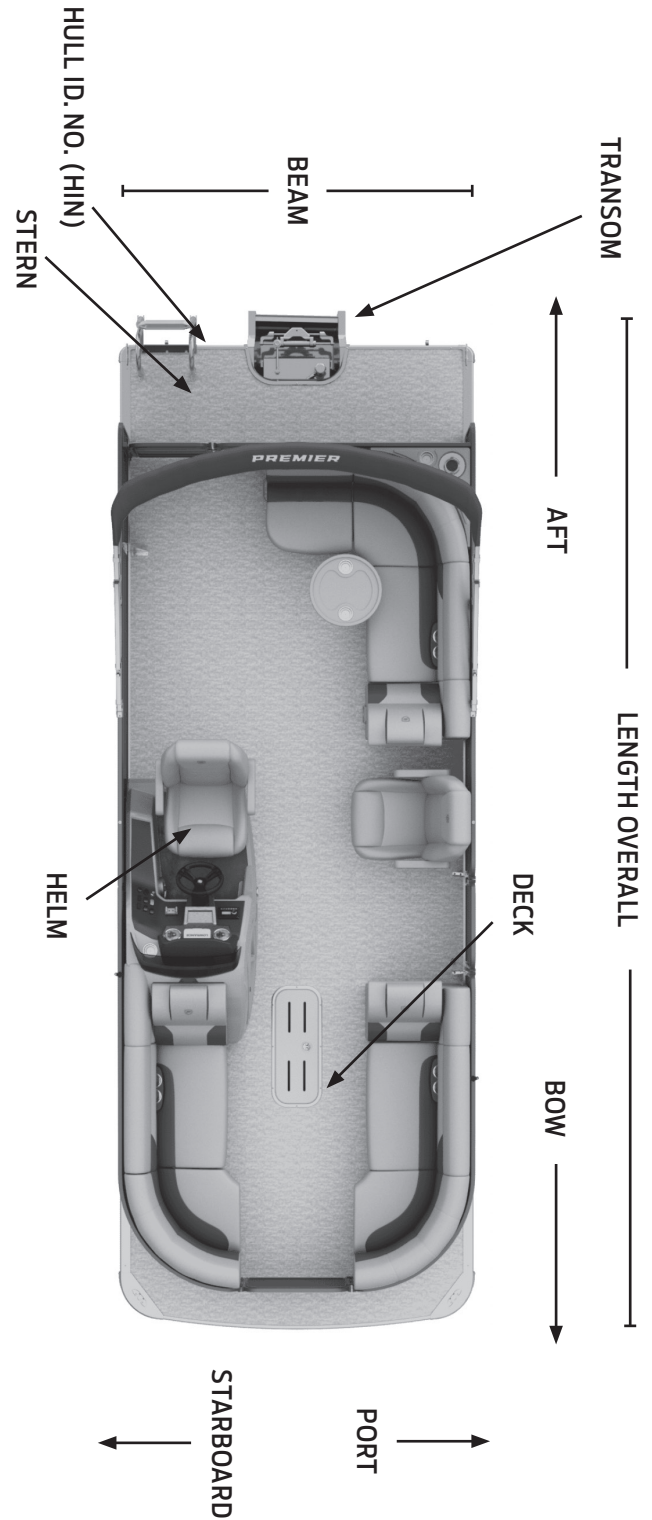

FIGURE 1-1 TERMINOLOGY

DESIGN FEATURES

Premier pontoons are some of the finest watercrafts available in the world. They are superior in technologically advanced engineering, maintenance, worry-free reliability and unrivaled performance. We use the finest materials available to make sure you have a boat that will give you years of boating satisfaction. We take pride in our ability to combine old-world craftsmanship with today's computer-enhanced manufacturing.

Your boat may have two or three tubes. We feature 28-inch, 32-inch, and 36-inch PTX center tubes. The outside tubes are 25-inches for better buoyancy and performance. A third tube increases buoyancy, reduces drag, and allows for a higher horsepower rating. Crossmembers are bolted to specially designed "M" brackets welded directly to the upper portion of the tube. "M" brackets provide greater stability and added strength for the crossmembers. Attached to the crossmembers is a specially developed marine grade plywood deck that guards against rot, decay, insect infestation and delamination.

Our rails are powder coated for protection from the elements. They are installed 1/4 inch (6.35 mm) above the deck for better drainage off the deck. Specially designed, heavy-duty braces provide extraordinary safety and add a margin of safety for passengers.

You can be sure that the electrical system will work. We use sealed wiring connectors below deck level designed to keep connections tight and moisture out.

We use composite or plastic material that reduces water retention, mold, rotting, environmental waste and pollution.

After your first outing, you will know that we built your boat for safety and long-lasting enjoyment.

SAFETY/HAZARD COMMUNICATION STATEMENTS

Three types of hazard communication statements used throughout this manual call attention to special information to help avoid dangerous situations and operate your boat safely.

A List of Warning Labels is available from customer service. These will be supplied free of charge as replacements for lost, removed or damaged labels.

Watch for the safety alert symbol. It means pay attention!



Your safety is involved! Failure to follow the recommendations in a hazard communication statement may result in property damage, personal injury or death.

The signal words DANGER, WARNING and CAUTION identify hazards and the levels of hazard seriousness. Their selection is based on the likely consequence of human interaction with a hazard in terms of the probability of injury and the degree of severity. Failure to follow the recommendations contained in any of these statements may result in some form of personal injury. Definitions for identifying hazard levels with their respective signal words are as follows:

DANGER

Immediate hazards that **WILL** result in severe personal injury or death.

WARNING

Hazards or unsafe practices that **COULD** result in severe personal injury or death.

CAUTION

Hazards or unsafe practices that **MAY** result in minor personal injury or product or property damage.

OWNER ADVISORY STATEMENTS

Advisory statements alert you to conditions that affect equipment operation, maintenance and servicing practices.

An **IMPORTANT** statement indicates a procedure intended to prevent damage to equipment or associated components.

A **NOTE** is a general advisory statement relating to equipment operation and maintenance procedures.

PROTECTING THE ENVIRONMENT

It's fun to be out on the water whether you're fishing, cruising, or just soaking up sun. Unfortunately, not all boaters are responsible individuals, and their foolish actions often spoil our waterways. Here are several ways you can help protect the aquatic environment as recommended by the National Marine Manufacturers Association. Practice them every time you go out, and you can help assure that our waterways will remain clean and unspoiled for years to come.

- Observe local and federal marine head rules.
- Remove waste from the holding tank (if your boat has one) on shore or have a trained person do it for you.
- Know about and use legal bottom paints.
- Use biodegradable cleaning agents whenever possible.
- Don't litter on or off the water. Take it home!
- Don't over fill fuel tanks and always clean up fuel spills.
- Watch your wake and propeller wash.
- Keep your motors finely tuned.
- When fishing, practice "Catch and Release."

GENERAL INFORMATION

This section of your boat manual contains important information about your Premier pontoon and general procedures to be followed before operating it.

Capacity Plate

Your boat is certified by NMMA (National Marine Manufacturers Association). It requires the manufacturer to install a capacity plate stating the maximum load in pounds (occupants and gear) the boat can safely carry under normal conditions, the maximum persons capacity, and the boat's maximum horsepower capacity. This applies to pontoon boats of all lengths.

The number of persons listed on the capacity label is calculated solely by a formula based on the displacement of the tubes. Boating conditions may require fewer occupants on board than indicated on the capacity label. Persons capacity is based on an average weight of 141 lbs. each (75 kg./165 lbs. in Canada) and, ultimately, the number of occupant positions on the boat.

You, the operator, are responsible for using common sense and sound judgment when loading your boat. Give yourself an added margin for safety in turbulent waters. Pontoon boats tend to remain stable under most operating conditions. Remember that overloading and improper distribution of weight are significant causes of accidents. Keep weight below maximum limits for safety in turbulent waters. Overloading is a violation of U.S. Coast Guard regulations.

WARNING

Do not exceed your boat's capacity rating. An overpowered or overloaded boat can become unstable, resulting in a loss of control or capsizing. An overloaded boat can become hard to handle. Overloading can also reduce freeboard and increase the danger of flooding or swamping, particularly in rough water.

IMPORTANT: Your Premier boat warranty will be voided if you exceed the recommended horsepower capacity or capacity ratings.

Hull Identification Number

Along with a capacity plate, each Premier boat has a hull identification number. The number on your pontoon boat is located starboard rear above the tube on the deck molding. This 12-digit or 14-digit number is a federal or international requirement. For example: PMY00000A000 or USPMY00000A000. It is used for registration, warranty and identification.

The Service/Maintenance Log provides a record of maintenance work completed on your boat, the date of completion, and the engine hour reading. This log also helps you identify the frequency of routine maintenance work such as engine oil changes. If you decide to sell your boat, it demonstrates to prospective buyers that you have done a good job of taking care of your boat.

Education

Courses on boat handling and seamanship are conducted by volunteer organizations such as the U.S. Power Squadrons, the U.S. Coast Guard Auxiliary, and the American Red Cross. These courses will sharpen your boating skills and bring you up-to-date on current rules and regulations even if you are a veteran boater. See Chapter 8 for more information.

BOAT DELIVERY RESPONSIBILITIES

When you take delivery of your boat, both you and your dealer have specific responsibilities.

Dealer

The dealer is responsible for the following:

1. Discussing the terms of all warranties and stressing the importance of registering warranties with the appropriate manufacturers.
2. Providing instructions for obtaining warranty service.
3. Going over the pre-delivery service record with you and then signing it to certify that all work has been done.
4. Providing you with thorough instructions in how to operate your boat and all of its systems and components. This should include a "walk-through" demonstration on your new boat.

Owner

As the owner, you are responsible for the following:

1. Signing off on the boat inspection sheet before delivery.
2. Scheduling an appointment with your dealer to go over all warranties. Helping the dealer complete the Premier Pontoon limited warranty registration and verifying that the dealer has registered the warranty with the factory within 10 days of the date of purchase.
3. Keeping a record of the hull number for future reference. The hull number is required most of the time when you must communicate with Premier Marine or your dealer.
4. Inspecting the boat at the time of delivery to ensure that all systems and components are working properly.
5. Scheduling an appointment with your dealer to go over the pre-delivery engine service record. Signing this record will indicate that your dealer has explained this to you.
6. Operating all equipment in accordance with the manufacturer's instructions. Reading all manuals and instructions supplied with your boat.
7. Referring to your engine manual for initial motor inspection and service requirements.
8. Performing or providing for the appropriate, periodic maintenance outlined in the Owner's Manuals and service guides.
9. Being a safe boater. Premier Marine recommends that all boaters take safe boating courses.

SAFETY/HAZARD LABELS

Some or all of the safety & warning labels shown in the below diagram and reference table on page (1.5) can be found in various locations on board your boat. The labels appropriate for your boat are determined by the standard and optional equipment actually installed on board your boat upon delivery.

The labels shown in the reference diagram (Figure 1-2) are just an example, the specific artwork, quantity, and location depends on the boat.

IMPORTANT: The Purpose of these labels is to prevent accidents, injury, or death. Make sure everyone on board reads and fully understands them!

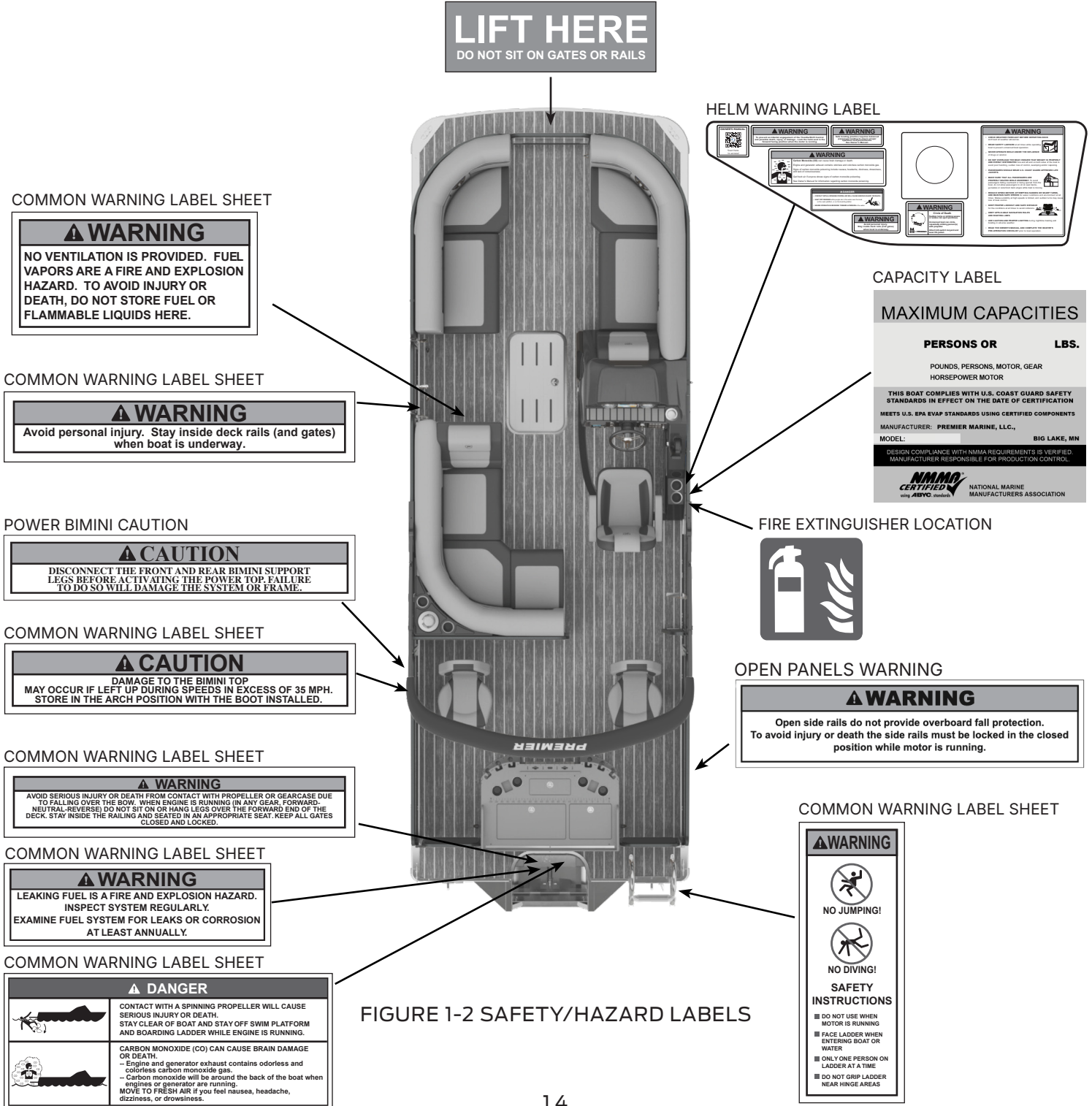

FIGURE 1-2 SAFETY/HAZARD LABELS

SAFETY/HAZARD LABELS

DESCRIPTION	LOCATION
WARNING - PINCH POINT	Placement not shown on diagram
WARNING - DO NOT STEP	Placement not shown on diagram
COMMON WARNING LABEL SHEET	Figure 1-2 (Various Locations - Other locations vary depending on boat)
HELM WARNING LABEL	Figure 1-2 (Helm)
WARNING - UPPERDECK CAPACITY 5	Placement not shown on diagram
DO NOT OCCUPY THE UPPER DECK WARNING	Placement not shown on diagram
WATER SLIDE WARNING LABEL	Placement not shown on diagram
POWER BIMINI CAUTION LABEL	Figure 1-2 (Bimini)
WARNING - UPPERDECK CAPACITY 3	Placement not shown on diagram
COOLER HATCH WARNING	Placement not shown on diagram
OPEN PANELS WARNING	Figure 1-2 (Open Water Panels)
COMMAND ANCHOR WARNING	Placement not shown on diagram
WARNING - RICOCHET STAIRCASE	Placement not shown on diagram (TWIN)
CAPACITY LABEL	Figure 1-2 (Helm)
TOW BAR CAPACITY	Placement not shown on diagram
CARBON MONOXIDE	Placement not shown on diagram
FIRE EXTINGUISHER LOCATION	Figure 1-2 (Helm) 2nd and/or 3rd locations vary depending on boat

Due to our part numbers being specific to the Layout, Model, and Year of the pontoon, we ask that you reach out to your nearest Premier Marine dealer to obtain the correct label for the specific area of the boat you are replacing them on. Please have the hull and engine serial numbers available to ensure the proper items are identified. If the dealer fails to respond to the request within 10 days, please email Premier Marine at customerservice@pontoons.com.

WARRANTY

Your new Premier boat is backed by a limited lifetime warranty and limited 10-year warranty. For a copy of the warranty please visit www.pontoons.com/owners. It is important to understand all the terms of the warranty. If you have a problem with your boat, contact your dealer immediately to determine warranty coverage. When you contact your dealer, please have the hull and engine serial numbers for the items needing repair readily available. If the dealer fails to respond to the problem, contact Premier Marine within 10 days by calling 763-207-2800 or emailing customerservice@pontoons.com.

There are many aftermarket accessories available for installation on pontoon boats. Premier Marine does not endorse or recommend many of those items since they can affect the operation, performance, and safety of your pontoon boat. The addition of certain items may void the warranty.

TRANSFER OF WARRANTY

The warranty transfer request from the original owner to the second owner must be applied for within thirty (30) days after the second owner purchase in order to validate the warranty transfer. A copy of the Bill of Sale or Purchase Order must accompany the warranty transfer request. This information should be provided to your Premier dealer. If you do not have a dealer, find your closest dealer at www.pontoons.com/find-a-dealer. Please provide your Premier dealer with original and second owners' full names. The new owner will be subject to a \$250 transfer fee.

EQUIPMENT MANUFACTURER MANUALS

Premier Marine purchased various equipment and components from other manufacturers and installed them on your boat while it was being built. The suppliers of standard and optional equipment maintain their own manufacturer's warranty and service facilities. Record all pertinent information for your records. Failure to register any part of your boat could result in loss or reduction of warranty.

Most OEMs (original equipment manufacturers) have also provided operation and maintenance manuals for your boat's equipment. Keep the OEM manuals with your Owner's Manual in a safe and accessible place. Pass them along to the new owner if you sell your boat.

Please note that, in some cases, information in this manual only summarizes more detailed information in the equipment manuals. Information in the OEM manuals takes precedence over information in this Owner's Manual.

OWNER RESPONSIBILITIES

Boating is an enjoyable and relaxing leisure time activity. However, responsibility is also a part of boating. You are responsible for, but not limited to, the following:

- Keeping boat covered when not in use to reduce over-exposure to UV rays, direct sunlight, and other environmental conditions
- Registering your boat with state authorities
- Registering the Premier warranty within 10 days of date of purchase
- Providing adequate insurance
- Obeying the rules of the road
- Know your state operator permit requirements.

- Proper maintaining and cleaning your boat and its equipment (including rinsing thoroughly with fresh water and ensuring good ventilation to allow materials to dry properly)
- Acquiring and maintaining safety equipment
- Safety training of passengers and crew
- Understanding the operation of boat systems and equipment
- Making seaworthiness/operational inspections
- Operating your boat safely
- Avoiding the use of alcohol and drugs
- Complying with environmental regulations
- Filing accident reports whenever it is necessary

Premier Marine recommends that all boaters take safe boating courses. We also believe that boaters have one more major responsibility—the environment. While you're out on the water, keep in mind the future of our waterways and the marine life that make them their home. Do everything you can to preserve the natural habitats we still have. Keep them free of garbage and debris. Preserving our waterways and habitats now can help assure the pleasure of boating for others for years to come.

BOATING LAWS AND REGULATIONS

Boat Registration

Every boat equipped with propulsion machinery of any type must be registered in the main state of usage. In nearly all states, this means registration with the designated state agency. In a few jurisdictions, the Coast Guard retains registration authority. All motorcraft not documented by the U.S. Coast Guard must display registration numbers. Registration numbers and validation stickers must be displayed on the boat according to regulations. Your Premier Marine dealer will either supply registration forms or tell you where they may be obtained. The registration agency will issue a certificate which must be aboard when using your new boat.

Some states and localities have limits on speed, noise and trailer specifications. It is your responsibility to be aware of these laws and limits and to be sure that your boat (and trailer) complies. Consult with your local Sheriff Marine Patrol, local Coast Guard office, or State Department of Natural Resources.

Insurance

The boat owner is legally responsible for any damage or injuries caused by the boat. In most states this is true even if someone else is operating the boat when the accident occurs. You should carry adequate personal liability and property damage insurance on your boat as you do on your automobile. You should also protect your investment by insuring your boat against physical damage or theft.

Discharge of Oil

The Federal Water Pollution Control Act prohibits the discharge of oil or oily waste into or upon the navigable waters of the United States or the waters of the contiguous zone (if such discharge causes a film or sheen upon or a discoloration of the surface of the water or causes a sludge or emulsion beneath the surface of the water). Violators are subject to penalties of \$5,000 or more.

Disposal of Plastics and Other Garbage

Plastic refuse dumped in the water can kill fish and marine wildlife and can foul propellers and water intakes. Other forms of garbage can litter beaches and make people sick. U.S. Coast Guard regulations completely prohibit the dumping of plastic refuse or other garbage mixed with plastic anywhere and restrict the dumping of other forms of garbage within specified distances from shore. Proper disposal of garbage helps protect our waterways and marine life.

Marine Sanitary Device

If your boat has a Marine Sanitation Device, it is illegal to discharge the waste into the water in most areas. You are responsible for being aware of and obeying all local laws concerning waste discharge. Consult with the Coast Guard, local marina or your dealer for information.

IMPORTANT!

The shrink wrap option is intended to be used as a means to keep your pontoon free from dirt and harsh weather elements during transportation. The shrink wrap is not a substitute for a storage cover.

Left in place, even if ventilated, shrink wrap can cause gelcoat finish problems from the condensation that builds up underneath the plastic; and can create scuff marks in the gel; or may cause railing damage from heavy rain or snow. Premier Marine will not warranty the damages caused by not removing shrink wrap upon delivery.

COMMAND ANCHOR BEST PRACTICES

- Always use the foot pedal to retrieve the anchor. When the anchor is nearing the boat, pulse the anchor slowly into place so it houses properly in the bow roller without causing damage or injury.
- Keep hands and feet clear of the anchor and windlass system when in use to avoid injury.
- Always ensure there is tension on the anchor rode when deploying or retrieving the anchor to avoid rope tangles.
- Open the ski locker door to ensure the rope is not tangled before and after use. Remove all weeds from the anchor and anchor rode.
- If anchor system power limit is reached, locate and reset the breaker under the port side center bed cushion (RL/RLO layout) or under the rear port couch corner cushion (RF layout).
- Refer to Lewmar manual for additional trouble shooting.

OCCUPANT POSITIONS

ABYC Standard H-35.5.3 requires the manufacturer to illustrate Occupant Positions. The illustrations reflect these Occupant Positions with an ● designating possible positions to be used when the boat is in motion at speeds in excess of 5 MPH (4.3 Knots). An Occupant Position is a **seated or standing** location with an **area of 16 inches within reach of a hand hold**. The railings are considered a hand hold. Please use the illustrations that are representative of specific models as a guide for safe operation of your boat. Make certain all passengers are aware of these locations. Never operate the boat with people outside the rails or gates, or improperly seated. All gates should be closed while underway. Never exceed the rated persons capacity posted on the Capacity label.

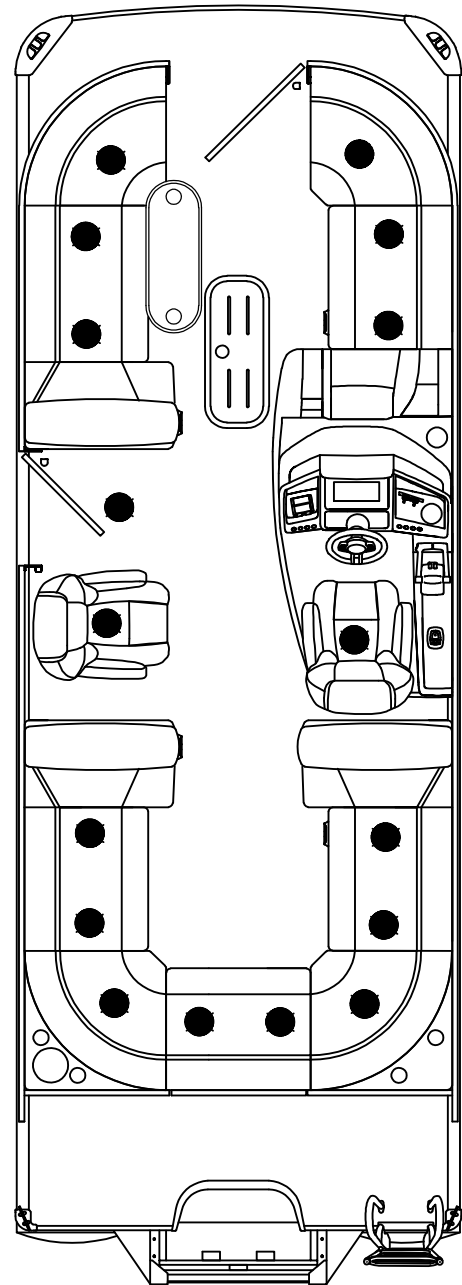

For Occupant positions by model, reference drawings on pages 1.8 - 1.10

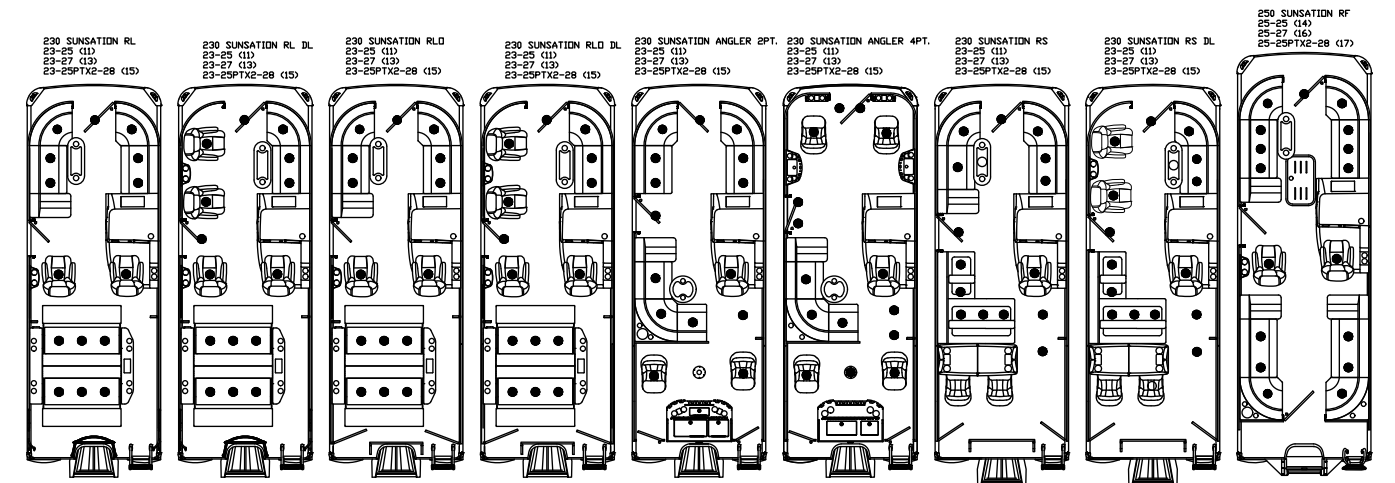
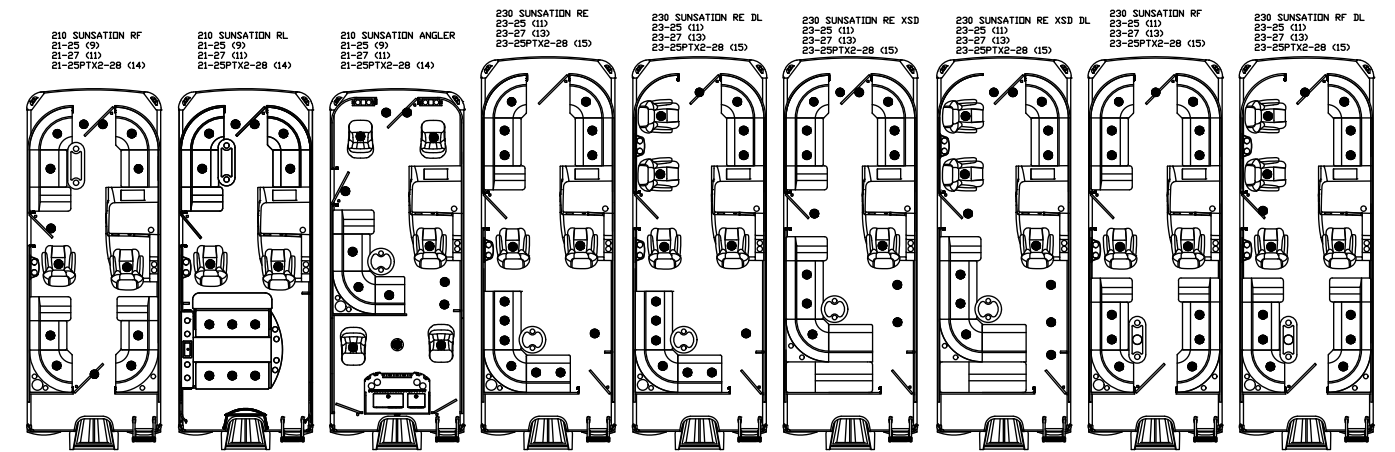
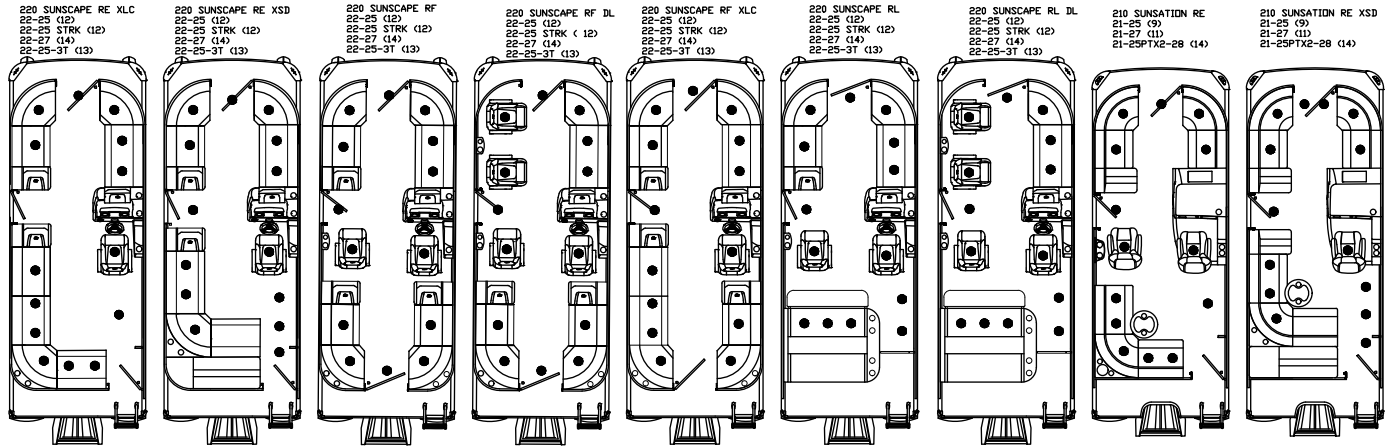
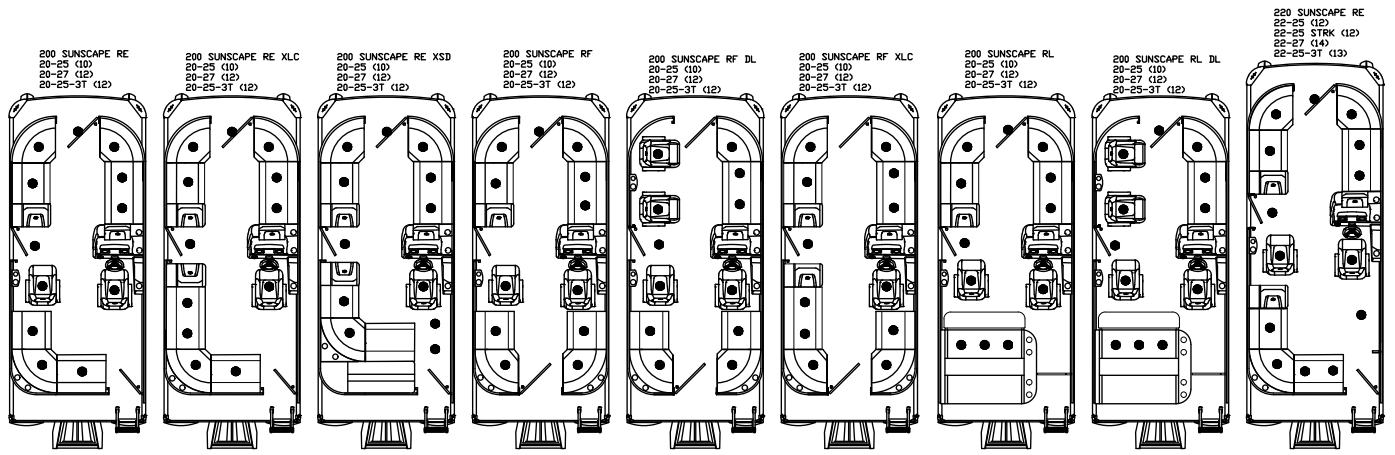

250 SUNSATION RF DL
23-25 (14)
23-27 (16)
25-25PTX2-28 (17)

250 SUNSATION RL
23-25 (14)
23-27 (16)
25-25PTX2-28 (17)

250 SUNSATION RL DL
23-25 (14)
23-27 (16)
25-25PTX2-28 (17)

250 SUNSATION RLD
23-25 (14)
23-27 (16)
25-25PTX2-28 (17)

250 SUNSATION RLD DL
23-25 (14)
23-27 (16)
25-25PTX2-28 (17)

250 SUNSATION ANGLER 2PT.
23-27 (16)
23-27PTX2-28 (17)

250 SUNSATION ANGLER 6PT.
23-27 (16)
23-27PTX2-28 (17)

250 SUNSATION RS
23-27 (16)
25-25PTX2-28 (17)

250 SUNSATION RS DL
23-27 (16)
25-25PTX2-28 (17)

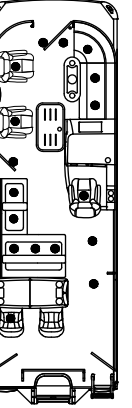
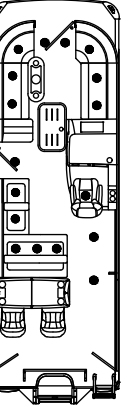
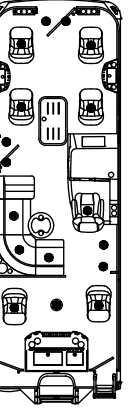
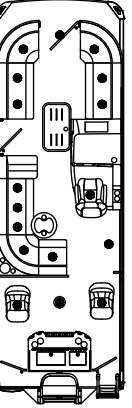
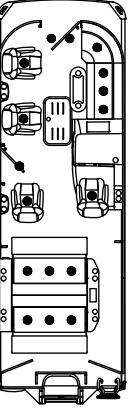
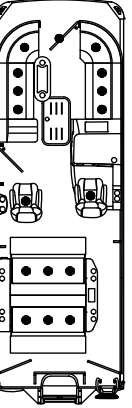
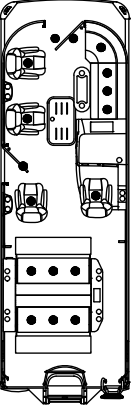
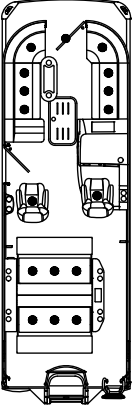
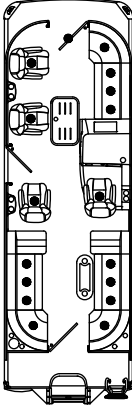

230 SCLARIS RF
23-25PTX2-28 (15)
23-27PTX2-32 (17)

230 SCLARIS RF DL
23-25PTX2-28 (15)
23-27PTX2-32 (17)

230 SCLARIS RL
23-25PTX2-28 (15)
23-27PTX2-32 (17)

230 SCLARIS RL DL
23-25PTX2-28 (15)
23-27PTX2-32 (17)

230 SCLARIS RLD
23-25PTX2-28 (15)
23-27PTX2-32 (17)

230 SCLARIS RLD DL
23-25PTX2-28 (15)
23-27PTX2-32 (17)

230 SCLARIS RS
23-25PTX2-28 (15)
23-27PTX2-32 (17)

230 SCLARIS RS DL
23-25PTX2-28 (15)
23-27PTX2-32 (17)

230 SCLARIS RF
23-25PTX2-28 (15)
23-27PTX2-32 (17)

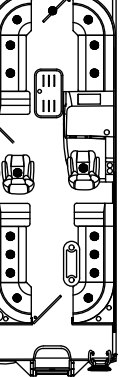
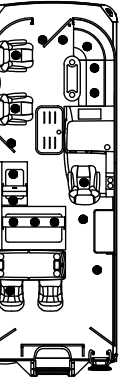
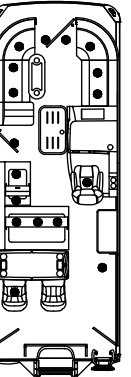
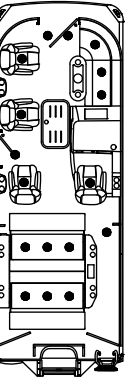
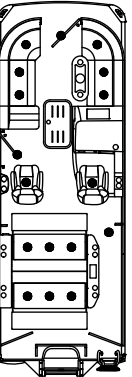
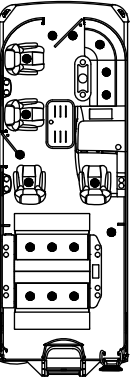
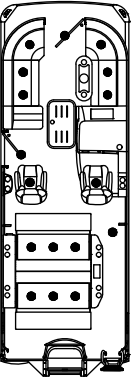
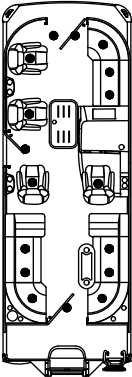
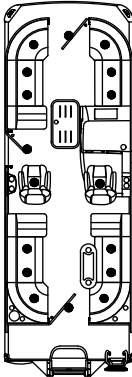

250 SCLARIS RF DL
25-25PTX2-28 (17)
25-27PTX2-32 (17)

250 SCLARIS RL
25-25PTX2-28 (17)
25-27PTX2-32 (17)

250 SCLARIS RL DL
25-25PTX2-28 (17)
25-27PTX2-32 (17)

250 SCLARIS RLD
25-25PTX2-28 (17)
25-27PTX2-32 (17)

250 SCLARIS RLD DL
25-25PTX2-28 (17)
25-27PTX2-32 (17)

250 SCLARIS RS
25-25PTX2-28 (17)
25-27PTX2-32 (17)

250 SCLARIS RS DL
25-25PTX2-28 (17)
25-27PTX2-32 (17)

250 SCLARIS UD
25-27PTX2-32UD (17)

250 SCLARIS UD DL
25-27PTX2-32UD (17)

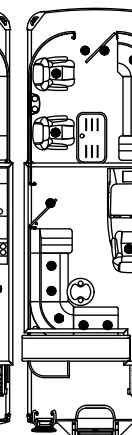
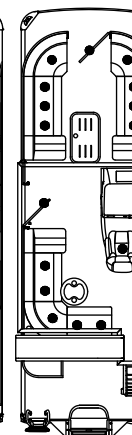
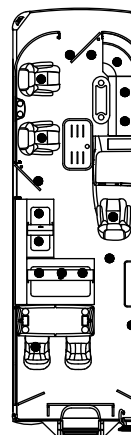
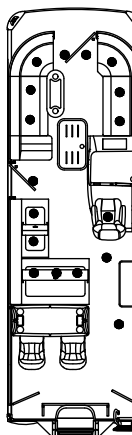
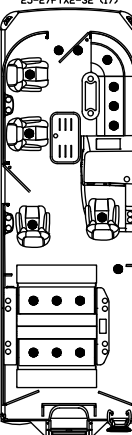
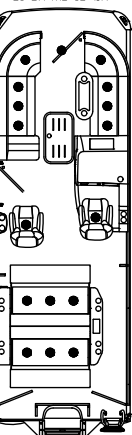
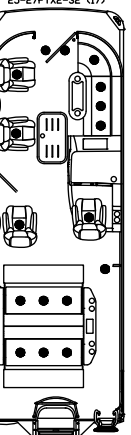
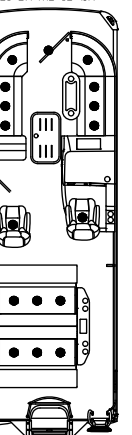
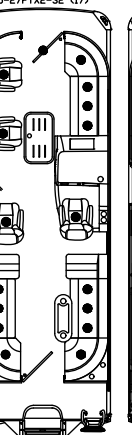

230 INTRIGUE RF
23-27PTX2-32 (17)
23-27PTX36-36 (17)

230 INTRIGUE RF DL
23-27PTX2-32 (17)
23-27PTX36-36 (17)

230 INTRIGUE RF GT
23-27PTX2-32 (17)
23-27PTX36-36 (17)

230 INTRIGUE RF GTS
23-27PTX2-32 (17)
23-27PTX36-36 (17)

230 INTRIGUE RL
23-27PTX2-32 (17)
23-27PTX36-36 (17)

230 INTRIGUE RL DL
23-27PTX2-32 (17)
23-27PTX36-36 (17)

230 INTRIGUE RL GT
23-27PTX2-32 (17)
23-27PTX36-36 (17)

230 INTRIGUE RL GTS
23-27PTX2-32 (17)
23-27PTX36-36 (17)

230 INTRIGUE RLD
23-27PTX2-32 (17)
23-27PTX36-36 (17)

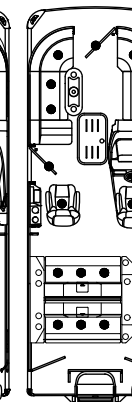
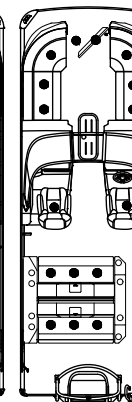
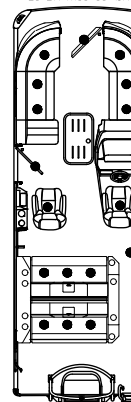
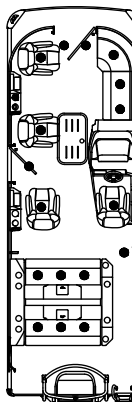
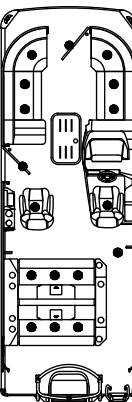
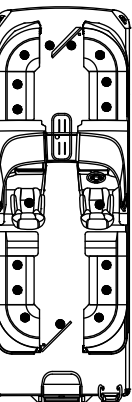
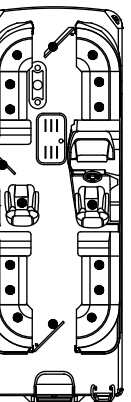
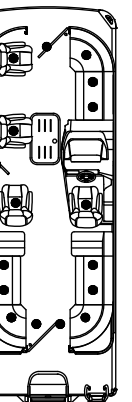
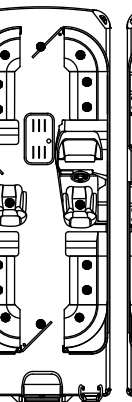

2 SAFETY

You should fully understand and become familiar with the operating procedures and safety precautions in this manual and the other information in the owner's packet before you launch your boat. Remember, "Safe boating is no accident." Always operate your boat with consideration, courtesy and common sense.

Before leaving on your boating excursion, be sure that all required safety items are on board. This includes the minimum required equipment and additional gear needed for your excursion. Regularly inspect all safety equipment to be sure it is in proper operating condition. Make sure all passengers know what safety equipment is on board, where it is, and how to use it.

SAFE BOATING RECOMMENDATIONS

Boating safety and the safety of your passengers is YOUR responsibility. You should fully understand all of the following safety precautions before you launch your boat.

- High speed maneuverability is limited. Sharp turns during high speed may cause loss of control. Understand the capabilities of your vessel and know they can change based on environmental conditions and loading.
- Never operate a boat while under the influence of drugs or alcohol. Doing so is a federal offense. Make sure only qualified drivers operate your boat.
- Keep your boat and equipment in safe operating condition. Inspect the boat, engine(s), safety equipment and all boating gear regularly.
- Be sure lifesaving and fire extinguishing equipment is on board. This equipment must meet regulatory standards, and it should be noticeable, accessible, and in safe operating condition. Your passengers should know where this equipment is and how to use it.
- Always keep accurate, updated navigation charts or equipment on board and available for reference and use.
- Before you leave shore, tell a family member, relative, friend or other responsible person ashore where you are going and when you expect to return.
- Do not allow passengers to ride on parts of your boat other than designated Occupant Positions areas. All passengers should remain seated while the boat is moving.
- Understand and obey the "Rules of the Road." Always maintain complete control of your boat.
- Do not occupy the front or back deck with feet in water while the motor is running.
- Do not operate your boat in excess of 30 MPH (in normal conditions) with Bimini top open.

- Do not operate your boat at unsafe speeds in rough water conditions.
- Never allow passengers to occupy an upper deck while boat is underway. Also adhere to the capacity limit of the upper deck. Overloading an upper deck will affect the boat's stability and may cause injury or even death.
- Do not overload or improperly load your boat. The capacity plate is only a guide. You must use good judgment. The capacity of your boat is reduced by turbulent water and other adverse weather conditions. This may require reduced seating in the bow. Check water and weather conditions before getting underway.

SAFETY GEAR AND EQUIPMENT

As the owner of the boat, you are responsible for supplying all required safety equipment. Check state and local regulations and the U.S. Coast Guard Boating Safety at www.uscgboating.org for information about required safety equipment. You should also consider supplying additional equipment recommended for your safety and that of your passengers. A list of this equipment appears later in this chapter.

Required Gear and Equipment

Most safety equipment required by federal regulations is provided as standard equipment on your boat, however, you are responsible for obtaining required safety equipment approved by the U.S. Coast Guard if it is not provided. Minimum requirements include the following:

- Personal Flotation Devices
- Fire Extinguisher
- Visual Distress Signal
- Navigation Lights (All Premier boats are equipped with navigation lights that satisfy this requirement.)
- Horn (All Premier boats are equipped with a horn that satisfies this requirement.)

PERSONAL FLOTATION DEVICES (PFDs)

You are required by Federal Regulations to have at least one Coast Guard approved personal flotation device (PFD) for each person in your boat. You may not use your recreational boat unless all your PFDs are in serviceable condition, are readily accessible, legibly marked with the Coast Guard approval number, and are of an appropriate size (within the weight range and chest size marked on the PFD) for each person on board. Your PFD provides buoyancy to help keep your head above the water and to help you remain in a satisfactory position while in the water.

Premier recommends that all persons wear Coast Guard approved personal flotation device while on board the boat. Make sure you check local and Federal requirements before boarding your boat.

PFD Type I, Wearable

(Figure 2-1) has the greatest required buoyancy. Its design allows for turning most unconscious persons in the water from face down position to a vertical, or slightly backward, face-up position. Type I is most effective for all waters, especially offshore when rescue may be delayed.



FIGURE 2-1 PFD TYPE I, WEARABLE

PFD Type II, Wearable

(Figure 2-2) turns its wearer in the same way as Type I, but not as effectively. The Type II will not turn as many persons under the same conditions as a Type I.



FIGURE 2-2 PFD TYPE II, WEARABLE

PFD Type III, Wearable

(Figure 2-3) allows the wearers to place themselves in a vertical or slightly backward position. It has the same buoyancy as a Type II PFD. It has little or no turning ability.



FIGURE 2-3 PFD TYPE III, WEARABLE

PFD Type IV, Throwable

(Figure 2-4) can be thrown to a person in the water, grasped and held by the user until rescued. The most common Type IV PFDs are a buoyant cushion or ring buoy. The throwable Type IV PFD should be immediately available for use and always in serviceable condition. This PFD is required in addition to the PFDs previously discussed.



FIGURE 2-4 PFD TYPE IV, THROWABLE

PFD Type V, Wearable

(Figure 2-5) must be worn. When inflated, it provides buoyancy equivalent to Type I, II or III PFDs. When it is deflated, it has little buoyancy. This PFD must be used according to the approval condition on the label and must be worn while underway.



FIGURE 2-5 PFD TYPE V, WEARABLE

FIRE EXTINGUISHER

All pontoon boats must carry at least one U.S. Coast Guard approved portable fire extinguisher. The extinguisher can be any one of the following: 2-pound (0.9 kg) dry chemical, 4-pound (1.8 kg) carbon dioxide, or 1-1/4 gallon (4.7 liter) foam extinguisher.

All hand portable fire extinguishers should be mounted in a readily accessible location away from the engine compartment. Everyone aboard should know where the fire extinguisher is and how to use it.

If your fire extinguisher has a charge indicator gauge, cold or hot weather may affect the gauge reading. Consult the instruction manual supplied with the fire extinguisher to determine the accuracy of the gauge.

SOUND SIGNALLING DEVICE

All vessels from 16.5 feet (5 m) to less than 39 feet (12 m) used only in US inland waterways shall be equipped with a certified horn. (This is standard equipment on ALL Premier models.) The horn/whistle shall have a fundamental frequency between 250 and 1750Hz and shall be capable of producing sound at the equivalent of 105 dB(A) at one meter (3.28 ft) from the sound source at an ambient temperature of 25+/-5.5 degrees Celsius (77+/-10 degrees Fahrenheit) within an intermittent time cycle of six seconds on, two seconds off, six seconds on, 106 seconds off, for a period of eight hours. The basic power source may be replaced. The device should be used to promote safe passing, as a warning to other vessels in fog or confined areas, or as a signal to operators of locks or drawbridges.

The following are standard whistle signals:

- One Prolonged Blast = Warning signal
- One Short Blast = Pass on my port side
- Two Short Blasts = Pass on my starboard side
- Three Short Blasts = Engines in reverse
- Five or More Blasts = Danger signal

NAVIGATION LIGHTS

Navigation lights are intended to keep other vessels informed of your presence and course. If you are operating your boat between sunset and sunrise, you are required to display appropriate navigation lights. All Premier models are equipped with the required navigation lights.

⚠ WARNING

Some states and local municipalities may not allow the use of certain colors present in the optional RGB lighting system. Failure to adhere may result in collision. Use the RGB controller to select lighting colors that follow all applicable regulations.

VISUAL DISTRESS SIGNALS

U.S. Coast Guard regulations require all recreational boats be equipped with visual distress signal equipment. The regulations apply to boats used on coastal waters, including the Great Lakes, territorial seas, and those waters directly connected to the Great

Lakes and the territorial seas, up to a point where the waters are less than two miles (3.2 km) wide, and to boats owned in the United States when operating on the high seas.

Visual distress signal equipment may be of the pyrotechnic or non-pyrotechnic type. The equipment must be approved by the U.S. Coast Guard, be in serviceable condition, and be stowed in a readily accessible location. Equipment having a date for serviceable life must be within the specified usage date shown. Careful selection and proper stowage of visual distress equipment is very important if young children are aboard.

No one signaling device is ideal under all conditions or for all purposes. Consider carrying various types of equipment on board. Approved pyrotechnic visual distress signals and associated equipment include red flares, hand-held or aerial; orange smoke, hand-held or floating; and launchers for aerial red meteors or parachute flares. Approved non-pyrotechnic equipment includes orange distress flags and electric distress lights.

RECOMMENDED ADDITIONAL GEAR AND EQUIPMENT

You should consider adding all or some of the following equipment. You may want to add other items depending upon your boating needs.

Basic Equipment

- Anchor and anchor line
- Signal flares
- 2 mooring lines
- Dock fenders
- Sunscreen
- Flashlight or portable searchlight
- First-aid kit
- Boat hook
- Oar or paddle
- Tow line
- Extra warm clothing
- GPS
- Compass
- VHF radio
- Foul weather gear
- Charts of the area
- Ring life buoy with line
- Cell phone
- Screwdrivers
- Adjustable wrench
- Electrical tape
- Pliers
- Spark plug wrench
- Lubricating oil
- Hammer
- Jackknife
- Duct tape
- Prop wrench
- Spare light bulbs
- Spark plugs
- Fuses
- Spare propeller
- Propeller nut and washer
- Flashlight batteries

SAFE BOATING PRACTICES

YOU are responsible for your own safety, the safety of your passengers, and the safety of fellow boaters.

Drugs and Alcohol

Drug and alcohol consumption, and boating do not mix! Operating under the influence endangers the lives of your passengers and other boaters. Federal laws prohibit operating a boat under the influence of alcohol or drugs.

Do not use drugs or drink alcohol while operating your boat. Like driving a car, driving a boat requires sober, attentive care. Operating a boat while intoxicated or under the influence of drugs is not only dangerous, it is also a federal offense carrying a

significant penalty. These laws are vigorously enforced. The use of drugs and alcohol, alone or in combination, decreases reaction time, impedes judgment, impairs vision, and inhibits your ability to safely operate a boat.

SAFE OPERATION

Safe operation means that you do not misuse your boat nor do you allow your passengers to do so. Safe operation means using good judgment at all times. It includes, without limitation, the following actions:

- Load your boat within the limits listed on the capacity plate. Balance loads bow to stern and port to starboard.
- Maintain boat speed at or below the local legal limit. Avoid excessive speed or speeds not appropriate for operating conditions.
- Do not use your boat in weather or sea conditions beyond the skill or experience of the operator or the comfortable capability of the boat or passengers.
- Be sure at least one other passenger is familiar with the operation and safety aspects of the boat in case of an emergency.
- Make sure that passengers and gear do not obstruct the operator's view or ability to move.
- Do not exceed the maximum engine power rating stated on the capacity plate attached to your boat.
- Do not operate in excess of 30 MPH (in normal conditions) with the Bimini top open.

Passenger Safety

Before getting underway, show all passengers where emergency and safety equipment is stowed and explain how to use it. Everyone aboard should wear shoes which resist slipping on wet surfaces and protect toes and feet from accidental injury. While underway, passengers should remain seated inside the deck rails and gates. Never allow them to ride on the sundeck or engine pod or in other unsafe positions. Never allow passengers to drag their feet or hands in the water. Always use hand holds or any other safety hardware to prevent falls.

Propeller

Never allow anyone near a propeller, even when the engine is off. Propeller blades can be sharp and can continue to turn even after the engine is shut off.

First Aid

As a boat operator, you should be familiar with basic first aid procedures that may be needed while you are far from help. Fishhook accidents or minor cuts and abrasions may be the most serious mishaps on board a boat, but you should also learn the proper procedures and be ready to deal with the truly serious problems like mouth-to-mouth resuscitation, excessive bleeding, hypothermia and burns. First aid literature and courses are available through most Red Cross chapters.

Operation By Minors

Minors should always be supervised by an adult whenever operating a boat. Many states have laws regarding the minimum age and licensing requirements of minors. Be sure to contact your state boating authorities for information.

Rules of the Road

As a responsible boater, you will comply with the “Rules of the Road,” the marine traffic laws enforced by the U.S. Coast Guard. Navigating a boat is much the same as driving an automobile. Operating either one responsibly means complying with a set of rules intended to prevent accidents. Just as you assume other car drivers know what they are doing, other boaters assume you know what you are doing. Chapter 8 has more information about navigational rules and the Rules of the Road.

Voluntary Inspections

State boating officials in many states or the U.S. Coast Guard Auxiliaries offer courtesy inspections to check out your craft. They will check your boat for compliance with safety standards and the required safety equipment. You may voluntarily consent to one of these inspections, and you are allowed time to make corrections without prosecution. Check with the appropriate state agency or the Coast Guard Auxiliary for details.

Safe Boating Courses

Your local U.S. Coast Guard Auxiliary and the U.S. Power Squadrons offer comprehensive safe boating classes several times a year. You may contact the Boat/U.S. Foundation at 1-800-336-BOAT (2628) or in Virginia 1-800-245-BOAT (2628) for a course schedule in your area. Also contact your local U.S. Coast Guard Auxiliary or Power Squadron Flotilla for the time and place of their next scheduled class. For more information on these courses, visit www.cgaux.org/boatinged/.

CARBON MONOXIDE

Burning a material containing carbon produces carbon monoxide (CO), an odorless and colorless gas. You cannot see or smell CO. Because it weighs the same as air, it will distribute throughout an enclosed space without your knowledge. Any device used to burn carbon-based materials on your boat, or those around you, can be a source of CO. Common sources of carbon monoxide include internal combustion engines and open flame devices such as charcoal grills.

The lungs absorb carbon monoxide which then reacts with the blood to reduce the blood’s ability to carry oxygen. The reduced oxygen supply to body tissues results in death of the tissue. Prolonged exposure can cause death.

In high concentrations, CO can be fatal within minutes. The effects of CO in lower concentrations are cumulative and can be just as lethal over long periods of time. Symptoms of CO poisoning include: itchy and watering eyes, flushed appearance, throbbing temples, inability to think coherently, ringing in the ears, tightness across the chest, headaches, drowsiness, nausea, dizziness, fatigue, vomiting, collapse, and convulsions.

If you observe any of these symptoms, begin treatment immediately. Prompt action can make the difference between life and death. Evacuate the area and move the victim to fresh air. Administer oxygen, if available, and get medical help. Open all canvas to ventilate the area. Investigate the source of CO and take immediate corrective action; be especially aware of sources adjacent to the boat.

⚠ DANGER

Carbon monoxide can be harmful or fatal if inhaled. Keep exhaust outlets clear of blockage. Provide adequate ventilation. Open hatches, doors, windows and vents to ensure adequate ventilation. Close engine compartment doors and hatches when engine or generator is running.

Carbon Monoxide Accumulation

The following are common situations in which carbon monoxide (CO) can accumulate within enclosed areas of your boat while docked, anchored or underway. Become familiar with these examples and their precautions and be alert to other situations to prevent CO poisoning.

⚠ DANGER

Generator or hull exhaust from other vessels while either docked or anchored can accumulate within enclosed areas of your boat. Be alert for generator exhaust from other vessels alongside (Figure 2-6).

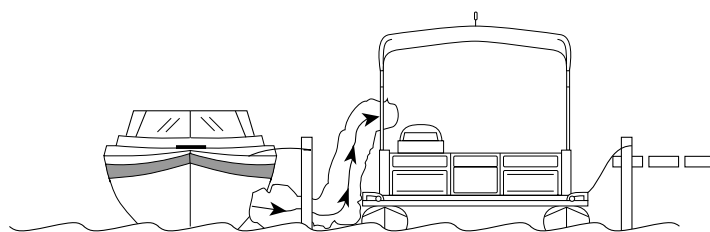

FIGURE 2-6 VESSEL ALONGSIDE

⚠ DANGER

Under certain conditions, tail wind, boat speed, or high bow angle can draw carbon monoxide into enclosed areas (backdrafting). CO can accumulate to dangerous levels without proper airflow. Open front canvas to provide adequate ventilation, redistribute the load, or bring boat out of high bow angle (Figure 2-7).

⚠ DANGER

CO in engine exhaust from your boat can accumulate within enclosed areas when your boat is operating at slow speed or stopped in the water. Installing rear canvas while underway increases the chance of CO accumulation in your boat. Tail wind can increase accumulation. Provide adequate ventilation or slightly increase speed if possible (Figure 2-7).

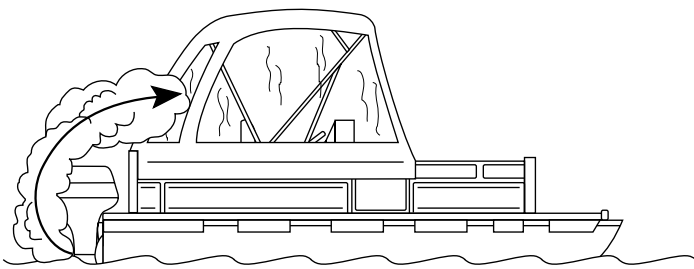

FIGURE 2-7 BACKDRAFTING

⚠ DANGER

With canvas in place, hull exhaust (while underway) can cause CO to accumulate within enclosed areas. Provide adequate ventilation when the canvas top, side curtains and/or back curtains are in their closed protective positions (Figure 2-8).

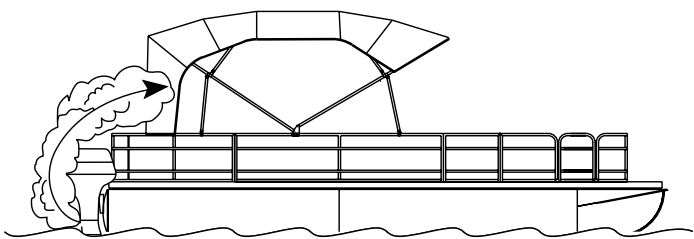

FIGURE 2-8 WHILE UNDERWAY

⚠ DANGER

When hull exhaust outlets are blocked by a pier, dock, seawall or any other means, CO can accumulate within enclosed areas. Make sure hull exhaust outlets are not blocked (Figure 2-9).

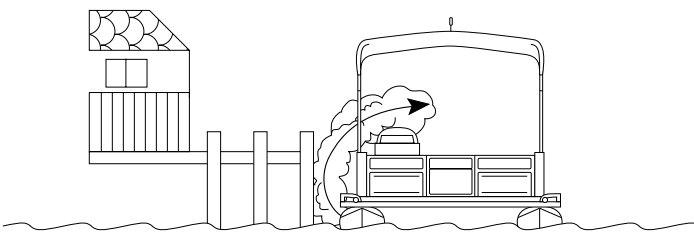

FIGURE 2-9 BLOCKED OUTLETS

Even with the best boat design and construction, CO may still accumulate in enclosed areas under certain conditions. Continuously observe passengers for symptoms of CO poisoning.

CO Detector

We recommend that you have marine grade CO detectors installed in boats with canvas enclosures. Monitors are available from your dealer. Monitors should be professionally installed and calibrated.

NOTE: A CO detector is not a gas fuel vapor detector. Gas fuel vapor detectors do not monitor the buildup of carbon monoxide in an enclosed area.

LANYARD STOP SWITCH

As of April 1, 2021, federal law requires the operator of a boat to use the lanyard stop switch.

NOTE: This component is supplied by the engine manufacturer. Refer to the engine Owner's Manual for detailed information about this switch.

⚠ WARNING

The lanyard stop switch must never be removed or modified and must always be kept free from obstructions that could interfere with its operation.

This safety device automatically stops the engine when the lanyard is attached to the operator and the operator falls or moves away from the control station. The stop switch (Figure 2-10) incorporates a shutoff switch, switch clip, lanyard and lanyard clip. The lanyard clip is securely attached to the operator's clothing, arm, or leg. Be sure to attach the lanyard to a place where it is free of obstructions and to something that will move with the operator if he or she leaves the helm station.

In order for the engine to run, the lock plate on the end of the lanyard must be attached to the engine stop switch. To reset the switch after engine shutdown, reinstall the switch slip above the interrupter switch and flip the interrupter switch.

New regulations require all boats to have secondary restart means. Engine manufacturers meet this requirement differently. Be sure to review your engine's secondary restart method.

NOTE: The switch on your boat may be different from the typical switch illustrated here. Refer to the engine manual for more information.

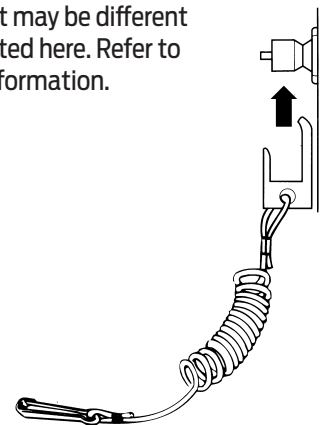

FIGURE 2-10 LANYARD STOP SWITCH

TOWER

Some boats are equipped with an optional tower. The tower is supplied with tool-less, hand operated star knobs used to lock the equipment in position. To avoid damage to the tower, ensure the star knobs are securely installed in either the raised or lowered position. Only remove star knobs when actively raising/lowering tower.

⚠ WARNING

Always use caution when powering arch/tower into desired position. As the operator, keep yourself, all passengers, gear, and furniture clear of tower and speakers to avoid any pinching or crushing hazards.

WATER SPORTS

Water skiing, wake boarding or riding a towed, inflatable apparatus are some of the more popular water sports. However, never exceed the limits of the ski bar. Also, never tow an airborne device or another vessel from the ski bar, they are over the limits of the ski tow bar. Tow bar is to be used for watersports and towable inflatables with a maximum of 2 riders and a combined weight limit of 340 lbs. Tow bar is not to be used for parasailing, kite flying or towing other boats. Taking part in any water sport requires increased safety awareness by the participant and the boat operator. If you have never pulled someone behind your boat before, it is a good idea to spend some hours as an observer, working with and learning from an experienced driver. It is also important to be aware of the skill and experience of the person being pulled.

⚠ WARNING

Your boat is not designed for and should not be used for pulling parasails, kites, gliders or any device which can become airborne.

Everyone participating in a water sport should observe these guidelines:

1. Allow only capable swimmers to take part in any water sport.
2. Always wear a personal flotation device (PFD) approved by the U.S. Coast Guard. Wearing a properly designed PFD will help a stunned or unconscious person stay afloat.
3. Always participate in water sports in safe areas. Stay away from other boats, beaches, swimmers and heavily traveled waterways.
4. Be considerate of others you share the water with.
5. Give immediate attention to a person who has fallen. He or she is vulnerable in the water alone and may not be seen by other boaters.
6. Approach a person in the water from the lee side (opposite the direction of the wind). Stop the motor before coming close to the person.
7. Turn off the engine and anchor your boat before swimming.
8. Swim only in areas designated as safe for swimming. These are usually marked with a swim area buoy. Do not swim alone or at night.
9. Stay at least 150 feet (45 m) away from areas marked by a diver down float (Figure 2-11).



FIGURE 2-11 DIVER DOWN FLOAT

Upper Deck and Water Slide

1. Observe capacity label and do not overload the top deck.
2. Do not occupy the upper deck while boat is under way.
3. Do not jump from the upper deck.
4. Do not use slide while boat is underway.
5. Shut off the motor before allowing slide use.
6. Make sure the water is in adequate depth and free of obstructions.

Water Skiing

The popular sport of water skiing has brought a special set of safety precautions to observe in boating. The following guides, in addition to the guides listed above, will do much to reduce the hazards while water skiing. For more information about water skiing, please contact the American Water Ski Association, 799 Overlook Drive, Winter Haven, FL 33884 (1-800-533-2972).

1. Water ski only in safe areas, away from other boats and swimmers, out of channels, and in water free of underwater obstructions.
2. Never allow anyone who cannot swim to water ski.

⚠ WARNING

Skiers must wear a USCG approved personal flotation device. A Type III water ski vest is an approved and practical PFD.

3. Have a second person aboard to observe the skier and inform the driver about the skier's hand signals (Figure 2-12). The driver must give full attention to operating the boat and the waters ahead.
4. Give immediate attention to a fallen skier. Always keep fallen skier on the operator's side of the boat when returning to attend the skier. Operators should always have fallen skiers in sight.

⚠ WARNING

Switch the engine off before taking skiers aboard from in the water. Do not leave the engine running in neutral; if the shift is accidentally engaged, the propeller can seriously injure the skier.

5. Do not water ski between sunset and sunrise. It is illegal in most states.

Hand Signals

1. Thumb Up: Speed up the boat.
2. Thumb Down: Slow down the boat.

3. Cut Motor/Stop: Immediately stop boat. Slashing motion over neck (also used by driver or observer).
4. Turn: Turn the boat (also used by driver). Circle motion with arms overhead then pointing in desired direction.
5. Return to Dock: Pat on the head.
6. OK: Speed and boat path OK, or signals understood.
7. I'm OK: Skier OK after falling.

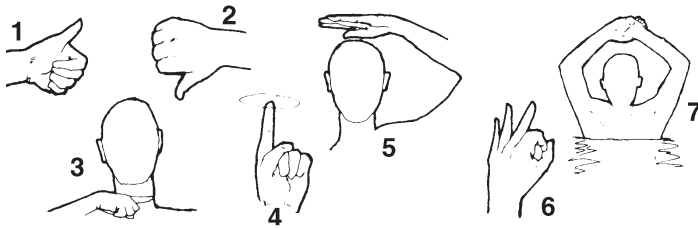
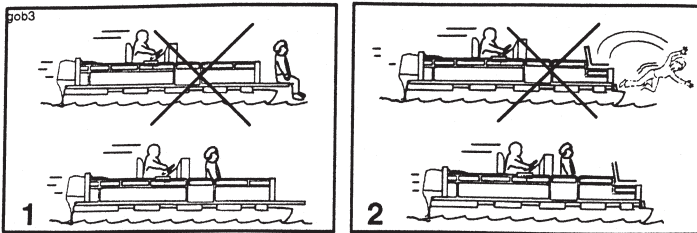

FIGURE 2-12 WATER SKIER HAND SIGNALS

PASSENGER SAFETY MESSAGE – PONTOON BOATS

Whenever the boat is in motion, observe the location of all passengers. Never allow any passengers to stand or use seats other than those designated for traveling faster than idle speed. A sudden reduction in boat speed, such as the result of plunging into a large wave or wake, a sudden throttle reduction, or a sharp change of boat direction could throw them over the front of the boat. Falling over the front of the boat between the two pontoons will position them to be run over by the motor.



1. Boats having an open front deck:

No one should ever be on the deck in front of the fence or rails while the boat is in motion at any speed. Keep all passengers behind the front fence or enclosure. Persons on the front deck could easily be thrown overboard, or persons dangling their feet over the front edge could get their legs caught by a wave and pulled into the water.

2. Boats with Open Water Panels:

Open Water Panels must remain closed and securely latched whenever boat is underway.

3. Electric Shock Drowning

Electric shock drowning is a result of low level alternating current passing through a body while immersed in fresh water. The current is sufficient to cause skeletal muscular paralysis, rendering the swimmer helpless.

While your boat may not have an AC electrical system, the boat next to you or the marina/dock may. Never swim in or around a marina.

4. Ladders

All Premier models are equipped with a stern boarding ladder. This ladder is meant to provide a means for unassisted re-boarding from the water. Ladders are mounted on the starboard aft area on single engine models or the center aft area on a twin-engine model. Please be mindful of the proximity to the motor(s) and never approach the ladder if the motor is running.

WATER SPORTS RESPONSIBILITY CODE

Be aware that there are elements of risk in boating, skiing, and riding that common sense and personal awareness can help reduce. Know your ability level and stay within it.

TO INCREASE YOUR ENJOYMENT OF THE SPORT,
FOLLOW THE WATER SPORTS RESPONSIBILITY CODE.

IT IS YOUR RESPONSIBILITY:

- ALWAYS familiarize yourself with all applicable laws, the risks inherent in the sport, and the proper use of equipment.
- ALWAYS know the waterways where you will be skiing or riding. Do not ski or ride in shallow water, near shore, docks, pilings, swimmers, or other watercraft.
- ALWAYS have a person other than the boat driver as an observer and agree on hand signals before starting.
- ALWAYS wear a U.S. Coast Guard type III (PFD) vest.
- ALWAYS read your Owner's Manual and inspect your equipment prior to use.
- ALWAYS ski or ride within your limits. Always ski or ride in control and at speeds appropriate for your ability.
- ALWAYS turn ignition off when anyone is near a watercraft power drive unit.
- NEVER operate watercraft, ski or ride under the influence of alcohol or drugs.
- NEVER "Platform Drag" or touch a swim platform while the engine is running.

For more information on boating, please visit:

- www.boatus.com
- www.wsia.net
- www.nmma.org

3 SYSTEMS AND COMPONENTS

This section provides information about your boat's electrical system, instruments, controls, and other equipment.

NOTE: Some of the equipment described in this chapter may be standard for some models and optional or not available for other models. Check with your Premier Marine dealer if you have questions about boat equipment.

ELECTRICAL SYSTEM

DC System

Your boat's electrical system is a 12-volt, direct current (DC) type similar to the system in an automobile. A battery or batteries supply power to the system. The battery is charged through an engine-driven alternator. A voltmeter at the helm dash shows the charge level of the battery. DC fuses or circuit breakers, also at the helm, operate 12-volt equipment. Turning the ignition switch off does not cut power to all components.

The battery's negative terminal is connected to the engine grounding stud. This type of negative ground system is the approved system for marine DC electrical systems. Critical circuits are protected by fuses.

The electrical system is wired at the factory to handle factory-installed electrical equipment. Premier Marine recommends that you have your dealer install any additional equipment. An error in wiring the electrical circuits can cause a fire or damage electrical system components. Have your dealer make electrical system repairs and install additional equipment.

If you do add additional equipment, it must be adaptable to the negative ground system. When installing additional equipment, be sure to take the power supply from the circuit breaker panel. All added electrical equipment must be properly protected by a circuit breaker or in line fuse on the positive wire. Be sure to protect all electrical components from rain, water, or sea spray.

NOTE: Power feeds for accessory equipment must NOT be taken from the voltmeter terminals. Consult with your dealer for additional DC power needs on your boat.

Battery Charger

Some models may be equipped with a battery charger. Refer to the manual supplied by the manufacturer of the charger for operation and maintenance information.

Battery or Batteries

The battery or batteries were installed on your boat by your dealer. Inspect frequently for cleanliness and tight connections.

If you need to replace a battery, install the same type as originally supplied with your boat.

If the starting battery is discharged, you can jump start the boat's engine. The battery cables do not need to be removed. Be sure to connect like terminals (for example, positive to positive). The last cable to be connected should be the negative cable of the charged battery. Before jump starting, determine the cause for the dead battery. In particular, check to see whether any switches or lights were left on and clean the battery terminals if needed.

⚠ WARNING

POISON! Batteries contain sulfuric acid and can cause severe personal injury if mishandled. Avoid contact with eyes, skin or clothing. In case of contact, flush with water for at least 15 minutes. If swallowed, drink large quantities of water or milk. Follow with Milk of Magnesia, beaten egg or vegetable oil. Get medical attention immediately.

When you install a battery, the connections must be made properly. Attach the positive cable to the positive (+) terminal, then attach the negative battery cable to the negative (-) terminal on the battery.

Charging the Battery

Batteries produce hydrogen and oxygen gases when they are being charged. These explosive gases escape through the vent/fill caps and may form an explosive atmosphere around the battery if ventilation is poor. This gas may remain around the battery for several hours after charging. Sparks or flames can ignite the gas and cause an explosion. Remove the battery and recharge it ashore.

⚠ WARNING

During charging, batteries produce gases which can explode. Explosion can shatter the battery. Battery acid can cause severe personal injury such as blindness. Keep flame, spark, and smoking materials away from the battery while charging. Charge the battery in a well-ventilated area.

Electrical Switches

Electrical switches control the power supply to boat components. Switches may be two-position (off or on) or three-position with a center off position. For three-position switches, the switch position determines which components are powered.

Your dealer should have explained all switches and controls for your boat during the delivery process. If you did not get a clear explanation or have forgotten the information, please call your dealer for assistance.

IMPORTANT: Some boat components, such as the stereo or refrigerator (if provided), are still powered even though the ignition switch is off. To prevent discharging the battery, turn off power to all components when they are not being used, or switch the battery switch to off if your boat has this feature.

INSTRUMENTS

NOTE: Some boat models do not have instrument panels. The instruments provided may vary from boat to boat. Instruments are listed in alphabetical order.

The instruments installed on your boat indicate current operating conditions for the engine and related systems. When you take delivery of your boat, ask your dealer about the normal readings of the gauges. This provides you with a reference point to evaluate how well your boat is operating. Keep in mind that the readings on some gauges tend to fluctuate. You should investigate the cause for gauge readings that show a continuous variance or a sudden, substantial variance from normal readings.

Fuel Gauge

The fuel gauge shows the approximate amount of fuel in the fuel tank. Note that the actual fuel supply may vary slightly from that shown on the gauge. The most accurate reading of the fuel gauge is at idle speed when your boat maintains an approximately level position. While underway, the fuel gauge usually indicates the tank is fuller than it actually is because the bow tends to be higher than when the boat is at rest. Since gauge readings are approximate, they should be compared to the hours of use versus known fuel consumption per hour.

The most common practice of good fuel management is the one-third (1/3) rule. Use 1/3 of your total fuel to travel to your destination, 1/3 to return, and keep 1/3 in reserve for emergencies.

Speedometer

The speedometer indicates the speed your boat is traveling across the water in miles per hour. In most cases water pressure from a water pickup at the boat's stern is measured and converted into a reading on the boat's speedometer.

Tachometer

The tachometer displays the engine's operating speed in increments of 100 revolutions per minute (RPM). The tachometer shows engine speed in RPMs under various engine operating conditions. Consult your dealer if you need more information.

Trim Gauge

The trim gauge indicates the relative position of the drive unit. Read this gauge carefully as it does not show the position of unit in degrees. Proper trim should be indicated by bow attitude and engine RPM. For more information see your engine Owner's Manual.

Voltmeter

The voltmeter shows battery voltage. If the engine is running at normal speed (1,000 RPMs or higher) and the alternator is charging, the reading on the meter ranges between 12.0 to 15.5 volts. If the meter reading is high when the engine is not running and the ignition key or switch is ON, the battery is fully charged. Significantly higher or lower readings indicate a battery problem, alternator malfunction, or heavy drain on the battery. Check the charging system and the battery system for the cause of these readings. An oscillating reading shows a loose voltage regulator connection or loose belts. Low voltage readings after stopping the engine indicate a bad battery or a heavy load on the battery. Refer to your engine owner's manual for proper gauge readings.

CONTROLS

Knowing how to use the controls on your boat is essential for safe and proper operation. The controls described in this section may be optional or may vary slightly from those on your boat.

Throttle and Gearshift

The controls on your boat may vary from model to model and depend on what kind of engine your boat has. The control described here is typical of the operation of most throttle/gearshift controls. Check the engine or control manual or see your dealer for more detailed information.

Twin and triple engine controls are more complex and may require pre-delivery adjustment and setting. Ask your dealer to fully explain your controls and read the information from the motor manufacturer.

A single-lever control integrates the throttle and gearshift into a single hand lever. It allows the operator to control both the engine operating speed and the forward and aft movement of the boat. This type of design ensures safe control of the engine with one hand.

The lever functions as a shifter during the first 15° of motion forward or back. Beyond 15°, it functions as a throttle. Pushing the lever toward the full throttle position increases engine speed.

Here are a few helpful operating tips:

- When shifting between forward and reverse, always pause in neutral for a few seconds before reversing propeller rotation to prevent damage to the engine and drive.
- When maneuvering at low speeds, you can reverse the throttle (move throttle forward or aft) to control or brake boat travel.
- Gradually increase speed when moving in reverse. High speed acceleration in reverse can create a wake, or hamper maneuverability.

WARNING

To prevent accidental engagement of the Throttle/Shift Control and possible death, injury, or damage - Lock the helm seat in the forward-facing position when the motor is running.

Steering

Various steering systems are used on Premier pontoons. All models are equipped with tilt steering wheels. Depending on the model, mechanical, hydraulic, and electric steering systems are available.

Getting the “feel” of your boat’s steering system is important. Steering does vary from boat to boat depending on the type of engine, water and wind conditions, and the load. Turn the wheel from full left to full right. Check that the drive unit is turning correctly, freely and smoothly. The cable output end of the steering system should be clear of fuel lines, control cables, electrical wiring, and outboard gear when an engine is moved through its full operating range.

You may find that trimming up your engine can improve steering. Excessive weight in the bow can cause steering to become more difficult.

All steering systems require periodic maintenance to be trouble-free and safe. Regular checks are essential. Check the cables regularly and tighten them as needed. Be sure to read the manufacturer supplied Operator’s Manual before heading out on the water.

Hydraulic Steering System

A hydraulic steering system is standard on most models. Hydraulic steering makes it easier to control the boat because the wheel is easier to turn. Operators should be careful that they do not “oversteer,” that is, turn the wheel too far so a turn is tighter than intended. See your dealer or the steering system manufacturer’s information regarding routine maintenance for this system.

There is also a power assist available on some types of hydraulic steering systems, which can make the steering much easier. See your dealer for availability and service information for your boat.

Power Trim

A power trim system is standard on all models. The power trim system controls the angle of the outboard motor. The power trim switch also allows the operator to adjust the motor at cruising speed to achieve an ideal planing angle. Moving the outboard in closer to the transom is called trimming “in” or “down.” Moving the outboard further away from the transom is called trimming “out” or “up.” Best performance is usually obtained when the front of the tubes are just slightly out of the water. Refer to the engine and control manuals for specific information about trimming.

To trim the bow of the boat up, press the trim switch in the direction marked UP. Moving the bow up increases top speed but can cause the boat to porpoise if trimmed up too far. Excessive trim up can cause propeller ventilation (propeller pushes air, not water).

To trim the bow of the boat down, press the trim switch in the direction marked DOWN. Running with the bow down helps the boat accelerate and get on plane faster, especially with a heavy load. It can also help improve the ride in rough water, but it reduces boat speed in most cases. Excessive trim down can make the boat difficult to steer, and trimming up can help make steering easier.

ELECTRONICS

Depth Gauge

This gauge provides a digital read-out of your water depth. Refer to the manufacturer’s Owner’s Manual for information about this instrument.

Fish Finder/Graph

The fish finder is a combined depth gauge and fish finder. Refer to the manufacturer’s Owner’s Manual for information about using this instrument.

Trolling Motor

An electric trolling motor is available as optional equipment on some models. Check with your dealer and refer to the trolling motor Owner’s Manual for operation and maintenance instructions.

Livewell

An aerated livewell is standard on some models. The livewell provides an environment where your catch can be kept alive and healthy. Figure 3-1 shows a typical livewell. The livewell on your boat may be slightly different than the one shown.

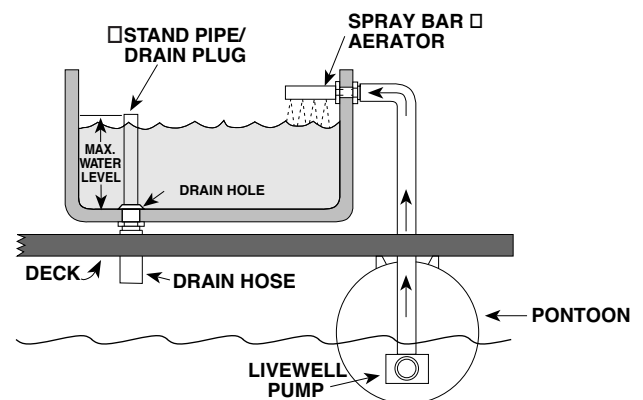

NOTE: LIVEWELL LOCATION VARIES BY MODEL

FIGURE 3-1 TYPICAL LIVEWELL

You should monitor water and air temperatures to determine when and how often you should aerate the livewell. You can turn the livewell pump on and off manually with the AER MAN switch. If you turn the switch to AER AUTO, a timer controls the operation of the pump.

The pump draws raw water in through a fitting below the waterline and pumps it into the livewell. The pump fills the livewell with raw water. Water sprays into the livewell through the aerator head. As the incoming water hits the surface of the water in the livewell, the water’s oxygen content increases which helps keep fish alive. As water continues to spray into the well, excess water flows out through the standpipe and drains overboard. Drain locations vary by model.

Do not operate the livewell pump dry. The pump is water-cooled and becomes overheated if no water is flowing through the pump.

If water does not come out of the discharge sprayer nozzle, stop the pump and correct the problem (for example, check for blown fuse, broken wires, closed flow control valve, plugged inlet). If the problem persists, check with your dealer.

If the overflow or drain becomes plugged, try back-flushing it with a garden hose set at low velocity. Some models have a screen at the pump intake. Remove the screen before back-flushing. Often, the obstruction will blow back into the livewell where it can be easily removed. Be careful that you do not use too much pressure. You can blow the hoses off the fittings.

Do not use the livewells to hold bait. Bait can be lost through or plug the drains.

Fresh Water Supply

A freshwater system is standard equipment on some models and optional on others. The manually pressurized freshwater system provides fresh water from a tank to the galley sink. Fill the tank only with fresh water. Refilling the tank often helps keep it a source of fresh and clean water.

CAUTION

Sanitize the water system regularly. Add 6 drops of Clorox bleach for each gallon of water. Flush this solution. Always provide adequate ventilation through the system and refill with fresh water.

Refrigerator

A refrigerator is available as optional equipment on some models. The refrigerator operates on a separate 12-volt DC power. When the refrigerator is on, carefully monitor power remaining in batteries. Turn off the refrigerator when batteries are low. Refer to the refrigerator manual for more complete information.

Portable Toilet

A self-contained portable toilet is available as optional equipment on some models. This portable toilet provides simple operation and convenient disposal of waste. The waste is transported off the boat by removing the holding tank. Dispose of the waste properly at a dump station or other appropriate location. Do not dump the tank's contents overboard. The unit is usually stored either under the sundeck or in the changing room. See the manufacturer's manual for safety precautions and detailed operation and maintenance instructions. A pump out system is offered on escalante models and is required in some areas. This system allows removal of waste by vacuum at some marinas.

AM/FM Marine Stereo

An AM/FM stereo receiver is available as standard on all models. The system has electronic circuits especially designed for radio reception on both AM and FM bands. When the stereo is not in use, be sure the switch is off to prevent drawing down the battery.

Features may vary on some stereo models. See the radio manufacturer's manual for a list of features and detailed instructions for use. The receivers and speakers are marinated to be used in high humidity and wet conditions. However, the cover should be used when necessary.

Display System

Your boat may be equipped with fishing finding/chart plotting/navigation system. This is a digital, touch screen control and operation system located on your instrument panel.

Specific operating instructions can be found on the original equipment manufacturers website.

CANVAS

Your boat may be equipped with protective coverings such as a Bimini top, ratchet cover, day enclosure, full enclosure, changing room, or a playpen mooring cover.

Ask your dealer to show you how to set up and store these coverings.

A boat covering, referred to as a playpen cover, is available as standard equipment on some models and optional equipment on others. This cover is secured to the boat using specially designed J-Clips™ (patented) which distribute the tension across a wide area of the canvas instead of confining it to a narrow area such as might be the case if a grommet were used. To prevent damage to the cover, install the J-Clip™ as shown in Figure 3-2.

When installing your covers with poles, verify that all poles are upright and thumbscrews or clamps are tight. Playpen cover models (J-clip style) are NOT trailerable. Trailering with this type of J-clip cover can result in damage to the cover, powder coated rails or other components that will not be covered under warranty. However, ratchet style cover models can be used during trailering. If traveling at highway speeds, stop periodically and check your cover and poles. Poles on all covers must be in the proper position to allow for best performance. Trailering during inclement weather such as high winds is not recommended and can cause damage that will not be covered under warranty.

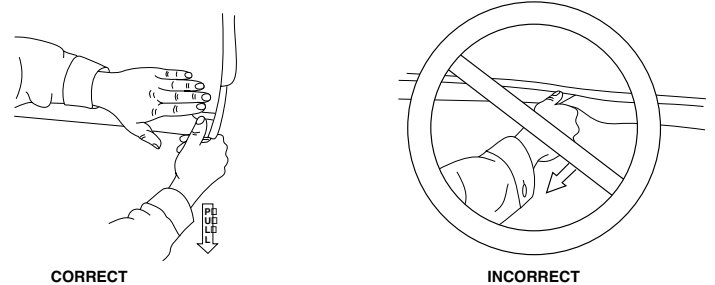

FIGURE 3-2 J-CLIP™

4 TRAILERING

A correctly selected trailer supports your boat properly, makes towing safer, and makes loading and unloading easier. Proper trailer selection and setup are very important. Improper trailering is one of the major causes of damage to the tubes. Your pontoon must be well supported to prevent any damage during trailering. The pontoon's weight should be supported the entire length of the tubes with a bunk trailer or the entire deck length with a mechanical folding trailer. Pontoon boats with outboard engines should have an engine support bar that extends from the lower unit to the trailer frame when trailering. Premier Marine will not be held liable for any damages caused by improper trailer setup or operation.

TRAILER

Gross Vehicle Weight Rating

Your trailer should be able to accommodate the weight of the boat, engine, full fuel tank and any other equipment normally carried. Check the certification label on the frame of the trailer for the Gross Vehicle Weight Rating (GVWR). The total weight of the boat, engine, fuel, gear and trailer should not exceed the GVWR.

Remember that the published weight is the dry approximate weight of your boat. Dry weight does not include the weights of outboard motors, batteries, gasoline, any optional items, gear or trailers. The weight of these items must be added to the dry weight to determine the proper trailer GVWR needed.

⚠ WARNING

The total weight of the trailer, boat and gear must not exceed the GVWR of the trailer. Overloading can cause accidents.

Weight Distribution

If your towing vehicle is equipped with a weight distribution hitch, it must be capable of handling the GVWR. The weight on the trailer should be evenly distributed and can be checked by determining the tongue weight.

Tongue weight is a percentage of the total weight of the loaded trailer on its tongue. Ideal tongue weight is not less than five percent (5%) and not more than ten percent (10%) of the GVWR. For example, if the weight of the loaded trailer is 3,000 pounds (1361 kg), the weight on the tongue should be more than 150 pounds (68 kg), but less than 300 pounds (136 kg). Excessive tongue weight causes the front end of the towing vehicle to sway. Insufficient tongue weight causes the trailer to sway or fishtail.

To avoid personal injury and property damage, be sure to balance the load when trailering. If too much weight rests on the hitch, the front end of the vehicle will sway or oversteer. Insufficient weight on the trailer causes the trailer to fishtail. In either case, the vehicle will be hard to handle and could become uncontrollable at high speeds. State regulations usually require that trailers above a specified weight rating be equipped with brakes.

Requirements vary; check with your dealer for additional information.

⚠ WARNING

The total weight of your loaded trailer must not exceed the capacity marker on the hitch of your tow vehicle. Overloading can cause hitch failure, leading to injury-causing accidents.

HITCH

Hitches are divided into classes that specify the gross trailer weight (GTW) and maximum tongue weight for each class. Always use a hitch with the same class number as the trailer. Most boat trailers connect to a ball hitch that is bolted or welded to the towing vehicle. Special heavy-duty equalizing hitches are necessary for trailer tongue weights of 350 lbs. (158 kg.) or greater.

The trailer hitch coupler must match the size of the hitch ball. The correct ball diameter is marked on the trailer coupler.

SAFETY CHAINS

Safety chains on the trailer provide added insurance that it will not become completely detached from the towing vehicle while underway. Crisscross the chains under the trailer tongue to prevent the tongue from dropping to the road if the trailer separates from the hitch ball (Figure 4-1). The safety chain should be of the "Proof Coil" type and must have a minimum breaking strength equal to the upper limit of the GVWR. Some states require chains to be locked so hooks can't shake, bounce or vibrate off the bracket.

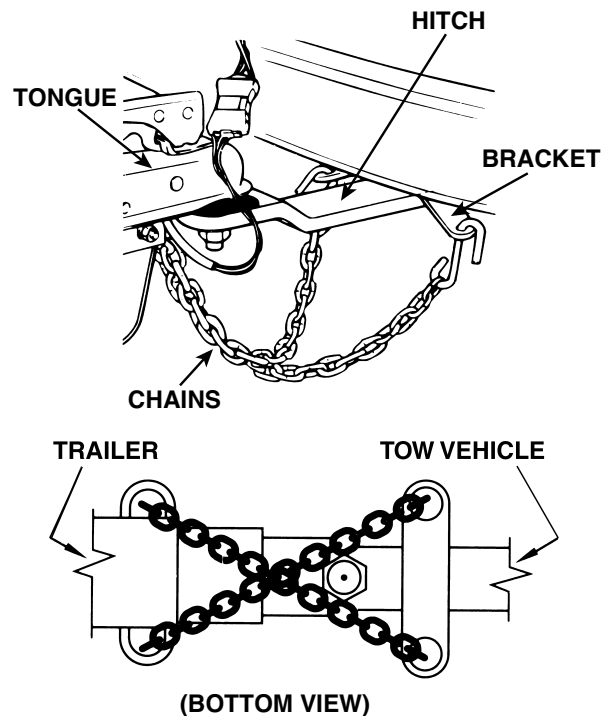

FIGURE 4-1 SAFETY CHAINS

TRAILERING GUIDELINES

1. Be sure that the bunks support all of the tubes and transom surfaces, and that they distribute weight evenly on the trailer. All transoms must be supported by the trailer to handle the weight of the engines.
2. Make sure your boat is properly tied down and a safety chain is used.
3. Do not trailer with the boat's Bimini top or other canvas up. Make sure the cover and gear are properly stored, and the optional trailering kit (available from your dealer) and sundeck are properly secured. Most of these items can be severely damaged while trailering if not properly secured.
4. Make sure the motor is tilted up and a transom saver is used. Don't travel without the motor properly tilted up or without a transom saver. Check the ground clearance of your lower unit.
5. Be sure your trailer is equipped with functional taillights and turn signals as required by state and federal laws.
6. Check with your state Department of Motor Vehicles for registration and licensing regulations in your state. Most states require that boat trailers be registered and licensed.
7. Be aware that a turn for the trailer is wider than a turn for the tow vehicle (Figure 4-2). When making a turn, be careful that your trailer does not strike another vehicle or object.

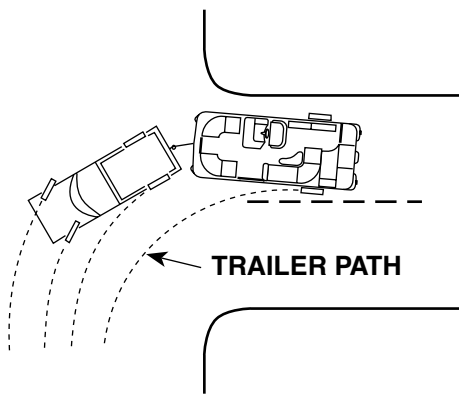

FIGURE 4-2 TURNING WITH A TRAILER

8. Inspect your trailer regularly to make sure the side supports are in good working order. Check the bolts which secure the rollers and supports for tightness. Check the wheel bearings frequently for sufficient grease.
9. Check local and state laws for any additional requirements for trailers.

BACKING A TRAILER

If you do not have experience in backing up with a trailer, practice backing with a trailer before you get into a confined launch site. Get accustomed to using your trailer in an open area. Take someone with you who knows how to back a trailer.

Backing a trailer works the opposite of backing a car. If the trailer needs to travel to the right, turn the steering wheel to the left and vice versa (Figure 4-3). Do not turn the wheel too far or oversteer. Turn the wheel gradually until you get the feel of safe backing.

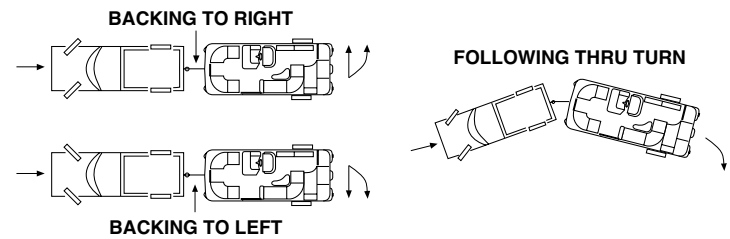

FIGURE 4-3 BACKING A TRAILER

LAUNCHING GUIDELINES

Before launching, stay to one side and watch a couple of launchings to notice any problems on the ramp and the effects of the wind and the current on launching. It's a common courtesy to prepare the boat for launching away from the ramp.

NOTE: If you have a bunk trailer, the boat's transom must be deeper than several inches in the water before launching.

Here are some tips to remember when putting your boat in the water:

1. Before backing down the launch ramp:
 - Remove all stern tie-downs.
 - Properly secure all loose gear.
 - Inventory your safety equipment.
 - Load all personal gear.
 - Lock winch and trailer unit.
 - Disconnect trailer wiring from towing vehicle to prevent short circuits caused by submersion.
 - Make sure drain plugs are installed.
2. Have an individual at the launch ramp give you directions. Back slowly down the ramp. If the trailer needs to be maneuvered to the right, turn the towing vehicle's steering wheel to the left. If trailer movement to the left is required, turn the steering wheel to the right. Always remember to launch your boat at a right angle to the shoreline.
3. If launching from a trailer, tilt the outboard motor up to the high tilt trailer position to avoid damage during the launch.
4. When the boat's transom is in several inches of water, stop the towing vehicle. If you have a manual transmission, leave it in gear. If you have an automatic transmission, shift to PARK.
5. Turn off the engine and set the parking brake.
6. Place blocks behind the vehicle's back wheels.
7. Do not detach the winch cable from the bow eye until a mooring line has been secured to one of the boat's cleats. Attach one line to bow and one line to the stern to help control the boat. See the Mooring information in Chapter 5 for suggested securing procedures.

8. Launch the boat; move it down and OFF the trailer into the water.
9. Secure the boat to a dock or have someone hold mooring lines.
10. Lower the outboard all the way into the water.
11. Pull your towing vehicle away from the launch ramp.
12. Park only in designated areas. When parking, be sure your towing vehicle and trailer do not block other boaters from approaching the launch ramp or hinder their ability to maneuver a boat and trailer when launching.
13. Remove all aquatic life and debris from your vehicle and trailer.

LOADING YOUR BOAT ON THE TRAILER

Follow these guidelines for loading the boat back onto the trailer:

1. Back the trailer into the water.
2. When the trailer is in several inches of water:
 - STOP the towing vehicle.
 - Leave manual transmission in gear or place automatic transmission in park.
 - Turn off the engine.
 - Set the parking brake.

NOTE: If you have a bunk trailer, the trailer may need to be more than several inches in the water before loading. If you find it difficult to load your boat, you probably have the trailer too deep in the water.

3. Tilt the boat's drive up to the high tilt position to avoid damage while loading.
4. Pull or drive the boat up onto the trailer and secure safety chain.
5. After securing the boat to the trailer, start engine on towing vehicle and pull trailer out of water to boat securing area. (If blocks are connected with a rope to the trailer tongue, you will not need to remove them before pulling trailer out.)
6. Use tie-downs to secure the boat on the trailer. Always use bow and stern tie downs to prevent the boat from shifting.
7. Wipe tubes down to prevent water spots and keep the boat clean.
8. Make sure everything in the boat is secure or tied down. Do not put other gear in the boat while trailering. Place anything loose in the towing vehicle.
9. Reconnect the trailer lights. Check that the lights are working.
10. Remove milfoil, zebra mussels, other aquatic growth and debris from pontoons, motor and trailer to protect and maintain our boating waters.
11. When boating in salt water or brackish water, wash down the boat completely with fresh water after each use.

CAUTION

DO NOT store boats on carpeted bunks or any other type of surface that can hold salt or any other chemicals near or on the surface of the boat. These surfaces WILL corrode and damage the boat.

CAUTION

DO NOT store boats by the lift strakes. This will damage the boat.

CUSTOM LIFT AND TRAILER MANUFACTURERS

If you're working with a custom manufacturer of boat lifts or trailers, please contact Customer Service at customerservice@pontoon.com. Please provide your boat's hull ID number (beginning with "PMY") and we will supply you with an accurate dimensional drawing.

Premier pontoons contain internal structural baffles located at the tube section welds and at several other points along the length of the tubes. **Proper support under these baffles is critical.** Any lift or trailer support that rests only between the baffles and does not continue fully to the tube-connecting welds can damage the pontoon.

PTX center tubes require full-length support. Because of their unique performance shape and structure, PTX center tubes must be supported from underneath along their entire length. When properly supported, the PTX sits flush at the keel with the two outer pontoons.

Deck-only support is not permitted for storage. Supporting the deck between the tubes without also supporting the pontoons or PTX underneath is not recommended for when the pontoon is not in use. This method is acceptable only for brief, short-term maintenance or repair work, such as pontoon replacement or lifting the boat with a forklift for dry-docking.

Attention:

Remember to always use a lower unit brace or transom saver while towing with an engine. The increased engine weight of 4-stroke motors makes this very important. Premier Marine does not warranty transoms due to trailer damage.

The use of playpen covers is also not recommended for use while towing. Wind resistance can cause the cover to stress and rip at high speeds. Premier Marine does not warranty damage to the boat or cover due to towing.

AQUATIC INVASIVE SPECIES (AIS)

Check the following items before transporting your boat:

- Trailer
- Axles
- Bunks
- Motor & Propeller
- Bilge & Motor well
- Livewells
- Anchor
- Dock lines
- Pontoon tubes
- Deck Crossmembers

5 UNDERWAY

BOATER'S CHECKLIST

Go through the following checklist before starting on your cruise.

- Will the weather be favorable? Did you get a current weather report?
- Is there a suitable licensed operator? Is operator impaired from drug or alcohol use?
- Are all passengers off the upper deck (if provided)?
- Are all passengers inside deck rails? Are all gates properly secured?
- Are tubes and propeller free of damage, excessive dirt and marine growth?
- Are electrical system and navigation lights working?
- Is the battery fully charged? Are connections clean and tight?
- Is your boat overloaded or overpowered (compared with capacity plate)?
- Is all required safety equipment on board? Does it work? Is there one PFD for each passenger? Is safety equipment easily accessible?
- Is the lanyard safety switch working?
- Is other equipment on board such as mooring lines, anchor and line, tool kit, first aid kit, etc.?
- Do you have enough fuel for your trip? Fuel tanks should be filled to slightly less than capacity. Allow space for fuel expansion.
- Have you checked fuel system for odors, leaks and deterioration?
- Have you checked the motor for leaks or signs of deterioration? Are fluid levels OK (engine oil, battery water, power steering fluid, etc.)?
- Is the engine free of obstructions? Are there any persons near the propeller?
- Does the steering system work smoothly? Are all components tight?
- Do you have navigation charts and equipment on board? Are you familiar with the area where you will be boating?
- Do passengers and crew know what to do in an emergency? Do they know how to use safety equipment?
- Do you have an emergency supply of food and water?
- Do you have all required documents on board?
- Have you told a responsible party ashore where you are going and when you expect to return?

This chapter provides basic information for a typical boating excursion. All boaters are responsible for their own safety and the safety of others. Even though you may be an experienced operator, you can still benefit from reviewing the boating principles discussed in this chapter. Before you get underway, make sure you are familiar with local and governmental boating regulations and restrictions.

NOTE: This chapter may refer to equipment and components that are standard on some models and optional or unavailable on other models.

FUELING

NOTICE

THIS BOAT IS EQUIPPED WITH AN EPA COMPLIANT FUEL SYSTEM. DO NOT ALTER OR BYPASS ANY OF THE COMPONENTS THAT ARE INSTALLED. SEE YOUR DEALER FOR ANY FUEL SYSTEM RELATED SERVICES.

The Environmental Protection Agency has passed legislation that will affect the way we design and build our boats for the 2012 Model year and beyond. The regulation is noted as (40 CFR Part 145). The regulation took effect on July 31st, 2012. It requires the manufacturers to substantially reduce the amount of Diurnal (daily) emissions that escape through the vessel's fuel system. There are different design solutions to this regulation.

We have implemented this fuel system into all current model year products as follows:

All models with permanently installed fuel systems are built with an EPA compliant non-permeable fuel tank.

To accomplish this, there are aspects of the fuel system design that must change over what you are currently accustomed to in Marine applications. The system is much closer to automotive fuel systems with the incorporation of secondary vents and vent hoses, new anti-spit-back fuel fill plates, audible fill caps, etc. There is also a requirement for expansion space (Ulage) that will decrease the actual fuel tank capacity by a small percentage.

WARNING

Use only gasoline up to E10 (Maximum 10% of Ethanol Content)

Never use gasoline with ethanol content higher than 10%, the use of gasoline with ethanol content higher than 10% can damage the engine and fuel system and will void the manufacturers warranty

If possible, fill the boat's fuel tank before loading passengers and gear. If passengers are on board, have them leave the boat until fueling is complete.

The use of a fuel stabilizer additive will greatly reduce engine problems and should be used all year.

Inspect the fuel system for leakage, weakening, hardening, swelling or corrosion of components including fuel tanks, fuel lines, fittings, fuel filters, and carburetors. If any component shows signs of leakage or deterioration, it must be replaced before starting the engine.

DANGER

Fuel vapors are explosive. Fuel leaking from any part of the fuel system can lead to fire and explosion that can cause serious bodily injury or death.

⚠ DANGER

Use caution when using blended fuels. The motor and/or fuel system was designed for fuels with lower levels of alcohol than may be available to you today. Fuels like E85 and E15 are very harmful to the fuel system in this boat. Do not use fuels like E85 and E15 because they may destroy or severely damage your fuel system or motor.

IMPORTANT: If 1/2 pint of gasoline explodes, it has the same power as 15 sticks of dynamite.

Before you start filling the fuel tank, securely moor the boat to a dock. Stop the engine. Extinguish all smoking materials. Turn off all electrical equipment, engines, lights, bilge blower, etc. Do not use anything that can produce a spark or flame. Always fill the tank in an area having adequate lighting. You may not see gasoline spills under poor lighting or in darkness. Make sure a fire extinguisher is readily available.

Follow these procedures to fill the tank:

1. Remove the fuel fill cap from the tank fitting and insert the fuel supply nozzle.
2. After pumping approximately 5-10 gallons (19-38 liters) of fuel into the tank, inspect the engine and fuel tank area for signs of fuel leakage. If fuel cannot be pumped into the tank at a reasonable rate, check for a plugged fuel vent or a kink in the line. Contact your dealer if slow filling continues. Never attempt to “overfill” the fuel tank as damage to fuel system components can occur.
3. If you find it necessary to fuel your boat from a can or unapproved fill nozzle, you may encounter difficulty filling your gas tank. Please contact your dealer to obtain a fill-assist device.
4. When you have finished fueling, replace the fuel fill cap. Listen for the “click” to ensure proper closure.
5. Open the fuel tank area. If canvas is in place, open it to ventilate enclosed area. Check for fuel fumes or fuel line leakage. Investigate and correct the source of fumes or fuel leakage before starting the engine.
6. Do not alter, modify or bypass any fuel system component. It may be illegal and void the warranty.
7. If you choose to add a portable tank:
 - Remove the tank from boat, remove the fuel fill cap from tank fitting, insert the fuel supply nozzle and begin pumping fuel.
 - Stop filling the tank before fuel overflows. Allow space at the top of the tank for thermal expansion. Fuel pumped from underground tanks is cooler than outside air. Gasoline expands as it warms up and can easily overflow the tank.

- When you have finished fueling, replace the fuel fill cap. If necessary, wash off any fuel spilled around the fuel fill area. Properly dispose of rags used to wipe off fuel spillage.
- Carefully carry the tank aboard and make fuel line connections. Check for fuel fumes or fuel line leakage. Investigate and correct the source of fumes or fuel leakage before starting the engine.

NOTE: Fuel fill volume varies with boat pitch. For maximum fuel capacity, avoid filling when the bow is pitched downward. Fuel gauge readings also change with pitch and are most accurate when the boat is level.

LOADING PASSENGERS AND GEAR

⚠ WARNING

Overloading and improper distribution of weight are significant causes of accidents. Capacity plates, located near the helm, show maximum loads under normal conditions. Keep weight below maximum limits for safety in turbulent waters. Overloading is a violation of U.S. Coast Guard regulations. All boats are subject to U.S. Coast Guard safe loading and labeling requirements.

The U.S. Coast Guard requires that a plate stating the maximum load capacity be affixed to all boats. This plate shows the load in pounds (occupants and gear) the boat can carry safely under normal conditions.

MAXIMUM CAPACITIES

13 PERSONS OR 1800 LBS.

2500 POUNDS, PERSONS, MOTOR, GEAR

150 HORSEPOWER MOTOR

THIS BOAT COMPLIES WITH U.S. COAST GUARD SAFETY STANDARDS IN EFFECT ON THE DATE OF CERTIFICATION

MEETS U.S. EPA EVAP STANDARDS USING CERTIFIED COMPONENTS

MANUFACTURER: PREMIER MARINE, LLC.,

MODEL: 24-25

BIG LAKE, MN

**DESIGN COMPLIANCE WITH NMMA REQUIREMENTS IS VERIFIED.
MANUFACTURER RESPONSIBLE FOR PRODUCTION CONTROL.**



**NATIONAL MARINE
MANUFACTURERS ASSOCIATION**

Powering and load capacities of pontoon boats follow the recommended practices of the American Boat Yacht Council, section H-35, and certified by the NMMA (National Marine Manufacturers Association). These capacities are based on formulas involving the length and volume of the pontoons as well as specific test procedures.

You, the operator of the boat, are responsible for using common sense when loading your pontoon. By their nature, pontoons may have less buoyancy at the bow. Do not overload passengers in the bow area. The person and gear load must be balanced. Special consideration must be given to aftermarket accessories such as “Sea Legs”, which are very heavy, will alter the balance and performance of the pontoon boat. Other add-on items may include trolling motors, additional batteries, anchor systems, or even heavy coolers. Have someone on the dock pass your gear aboard. Secure all gear firmly so that it will not move or interfere with boat operation. Be sure all required safety gear is aboard and easily accessible. The proper way to distribute the weight of the passengers is to arrange them so that there is less weight at the bow. Bow pedestal seats are not to be occupied while the boat is underway. This helps to ensure that water does not wash onto the deck during certain water conditions.

CAUTION

Wet surfaces can be slippery. Passengers should wear adequate deck shoes while boarding and underway to avoid accidental slipping and injury.

Passengers should board the boat one at a time. Always step onto the boat, never jump. Check that all passengers are seated in a proper seat. Do not allow passengers to ride outside the deck rails or on the sundeck. Falls from moving boats are a major cause of marine accidents.

WARNING

Passengers occupying swivel or high platform seats may be thrown overboard while accelerating or during sharp turns when running at speeds greater than trolling speed. Injury or drowning is possible. Be sure all passengers are seated properly. Follow instructions stated in safety labels on seat posts.

Be sure all passengers are seated properly. Swivel and pedestal form seats may turn suddenly while underway. Those seats are equipped with lever locks to prevent the seats from turning freely. These locks must be engaged while the boat is moving faster than trolling speed. Swivel seats within 4 feet of the front rails should not be occupied while boat is moving faster than trolling speed. All passengers should remain seated in an appropriate seat while boat is moving, even at trolling speeds. Seats designed for use at cruising speeds are stationary, have a locking handle, or have a lever lock. For seats with a locking handle, engage the lock by flipping the handle to keep the seat from swiveling.

WARNING

Do not occupy the upper deck while the boat is underway. Do not jump from the upper deck at anytime. Observe upper deck capacity limits. Never use the slide while the engine is running.

STARTING THE ENGINE

The following information is merely a guide and not intended to explain in detail all starting procedures and instructions. Refer to the engine Owner’s Manual for detailed pre-start and starting instructions specific to your boat’s engine.

Outboards:

1. Secure the boat to the dock or mooring slip before attempting to start the engine.
2. Lower the outboard to the run position. Make sure all cooling water intake holes are submerged.
3. Check the fuel supply to ensure you have enough fuel for your expected travel plan.
4. Attach stop switch lanyard to the operator. See engine Owner’s Manual for specific instructions.
5. Make sure throttle is in the neutral position.
6. If you are starting a cold engine, move the fast idle lever to mid-position.

NOTE: The engine will not turn over if shift lever is engaged. If the engine does not turn over, the shift lever may not be in neutral. Move the throttle lever up and down slightly and try again.
7. If the engine is equipped with a carburetor, run the engine approximately 1-2 minutes at fast idle speed (1200 to 1500 RPM) to warm up the engine. Keep the boat secure at the dock until the engine is warmed up. Return the fast idle lever to the neutral position after warm-up.

LEAVING THE DOCK

After the engine has warmed up, you are ready to leave the dock. Before you cast off, check all gauges for proper readings. If the oil pressure reading is abnormally low, or the temperature reading is abnormally high, stop the engine immediately. Check the operation of the steering by turning the steering wheel to full port and to full starboard while observing out motor movement. With boat still securely moored to the dock and engine idling, move the throttle forward, then aft, then back to neutral to check for proper shifting. Check wind, tide and current or other forces that will affect the way you maneuver your boat away from the dock. Release the mooring lines and stow fenders.

When you have completed these pre-departure checks, shift your boat’s engine into forward or reverse depending on whether you want to move the bow or the stern away from the dock first. Move the throttle lever to neutral, then push forward quickly and firmly to shift into forward gear or pull back to shift into reverse. Your engine should be running at a slow speed as you move away from the dock. If you move the bow out first, watch that the stern does not swing into the dock or a piling.

⚠ WARNING

Passengers are to remain seated while casting off and underway. Sudden or unexpected movements may cause passenger to fall. Make sure passengers seated ahead of the helm console do not obstruct driver's vision.

STEERING

Boat steering is not self-centering. Steering is affected by engine and propeller torque, trim tab setting, wave and current action, and the speed of the tubes through the water. Constant attention to steering is required for safe operation.

Watch the stern when you turn! Steering a boat is like driving a car with rear-wheel drive on slippery pavement (Figure 5-1). When you turn the steering wheel, the stern responds first by swinging in the opposite direction of the bow. When you are leaving the dock or trying to avoid an object in the water, this swing can be critical. Trimming your engine can make steering the boat easier. Be sure to balance your passengers. Too much weight in the bow can make steering more difficult.

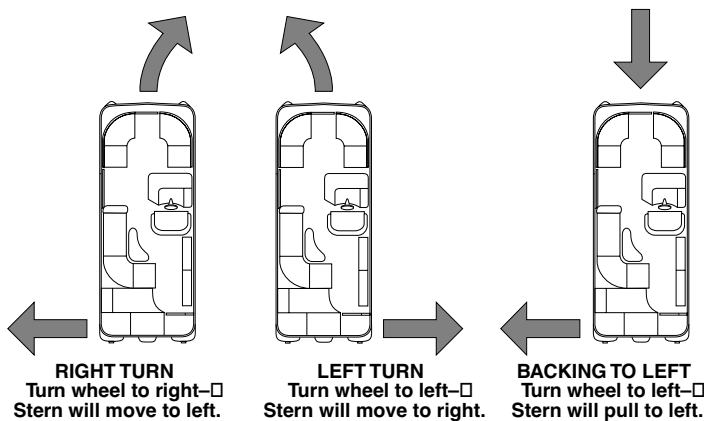

FIGURE 5-1 STEERING

Always give yourself plenty of room to make a turn. You should also slow the speed of your boat while turning. Never make sharp, fast turns because you can easily endanger your passengers or lose control of your boat.

When making tight turns, trim the engine in for better handling. Since both the thrust and steering are at the stern of the boat, the stern pushes away from the direction of the turn. The bow follows a smaller turning circle than the stern (Figure 5-2).

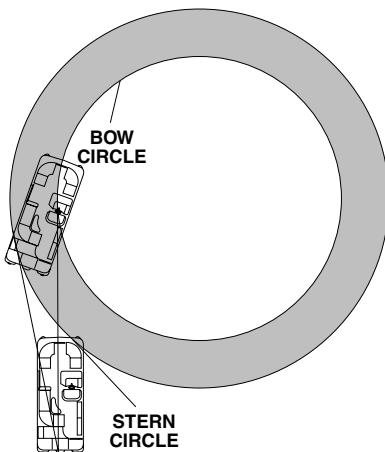

FIGURE 5-2 TURNING

BOAT SPEED

The maximum speed at which you can make sudden turns without losing control of your boat is called the maneuvering speed of your boat. Maneuvering speed varies depending on wind, waves and other factors. Some boats display a warning advising that maneuverability above a given speed is limited. This speed is based on tests in calm water. There are minimum safe speeds for certain conditions as well, maintaining headway in a cross wind, for example. Some careful experimentation will serve you well later on. When you encounter a potentially hazardous situation, adjust speed accordingly.

Pace your speed so that you have enough time to respond to an emergency. Never drive your boat directly behind a water skier in case the water skier falls. For example, at 25 miles per hour (40 km/h), your boat travels more than 35 feet per second (10.7 m/s). If a skier falls 200 feet (61 m) ahead, your boat will overtake the fallen skier in less than 6 seconds.

ACCELERATING

⚠ CAUTION

Acceleration at full throttle is not recommended during the motor break-in period. Refer to the Owner's Manual for the correct way to break in your boat's motor.

When you throttle up and accelerate, your boat increases the trim angle which causes the boat to ride bow high. Get on plane as quickly as possible. It should only take a few seconds at full throttle for your boat to level out. Accelerate until you reach a comfortable plane then throttle down to cruising speed. This also provides for better fuel efficiency.

TRIMMING

The following summarizes general principles for trimming your boat. For a more detailed discussion of trimming, refer to your engine Owner's Manual about the trim controls installed on your boat.

The outboard must be trimmed to adjust to the ideal boat angle for given load and water conditions. The outboard should be trimmed so that it is perpendicular to the water when the boat is running at full speed (Figure 5-4).

On two-tube boats, trimming the motor does not significantly affect boat attitude, but it does improve engine efficiency. On the other hand, a triple tube PTX™ boat rides higher in the water, accelerates more rapidly, and is more responsive in turns. Trimming is more likely to affect boat attitude, but the effect will be less than trimming a boat with a planing hull.

On boats equipped with power trim controls, trim can be adjusted while running. Trimming out or up lifts the bow upwards and generally increases top speed. Excessive trimming up can cause ventilation (Figure 5-3). Trimming down can cause the front of the tubes to plow through the water and can slow the boat down, a slight “up” trim angle is generally desirable. Adjusting trim to existing conditions while underway is necessary for good performance (Figure 5-3). The trim gauge is a general guide only, and accuracy of the gauge may vary from motor to motor. See your dealer to see if your gauge can be adjusted. Trim cannot be adjusted while running on boats equipped with a manual tilt system.

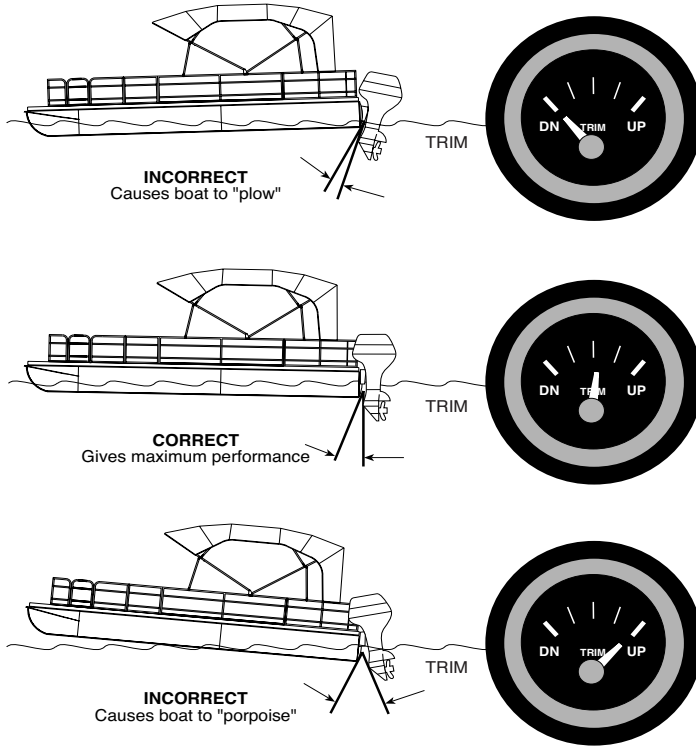

FIGURE 5-3 TRIMMING

You can quickly correct minor deficiencies in your boat’s ride by shifting passengers and gear forward or aft. Shifting weight has the same effect as changing the angle on the drive unit. By taking a little extra time to carefully place such items as coolers, water jugs and the anchor, you can create a more desirable trim.

⚠ WARNING

Any passenger changing position while underway must be very careful to prevent injury or falling overboard. If passenger position must be changed, operator must first reduce speed.

At low idle speed, an outboard can be tilted up past trim range to permit operation in shallow water. However, the engine’s cooling water intake holes must always remain submerged. Otherwise, the engine will overheat.

⚠ CAUTION

Use extreme caution when operating with drive unit raised. Cooling water intake holes must remain submerged. See Owner’s Manual for details.

GENERAL RULES OF SEAMANSHIP

1. Cross waves at right angles.
2. When caught in heavy water or squalls, head either directly into the waves or at a slight angle. Reduce speed, but maintain enough power to maneuver your boat safely.
3. Keep your speed under control. Respect the rights of boaters engaged in fishing, swimming, water skiing or diving. Give them “wide berth.” Never follow behind a water skier.
4. When meeting a boat head-on, keep to the right whenever possible.
5. When two boats cross, the boat to starboard has the right of way.
6. When overtaking or passing, the boat being passed has the right of way. The boat being passed is required to maintain the same course and speed.

STOPPING

You cannot stop a boat as quickly as a land vehicle because a boat has no brakes. Stop the boat by allowing it to slow down to less than 5 miles per hour (8 km/h). Then, put the engine in reverse. By slowly increasing reverse power, you can stop the boat in a short distance. Remember that the boat does not respond to steering in reverse as well as it does when going forward.

ANCHORING

Anchor your boat if you stop for recreation or an emergency. The size and weight of your boat govern the weight of the anchor and the diameter of the anchor line. A burying anchor grips into the bottom and holds your boat secure. Holding power should be more important than weight. Your dealer can help you select the proper anchoring equipment.

The length of the anchor line should be six to eight times the depth of the water to assure that the anchor bites into the bottom. The bottom end of the anchor line should be galvanized chain. The rest of the line should be a nylon anchor line.

Keep anchor secure while underway to prevent damage or injury if the boat’s attitude changes suddenly. If your boat has a power winch, do not use it as the primary source for securing the anchor or anchor line. See the power winch instruction manual for details about proper operation and maintenance.

These are some general guidelines for anchoring your boat:

- Secure the anchor line to the deck cleat or tube eyes. Do not tie line to hardware or a railing not designed to support this stress.
- If you are anchoring for more than a few hours, use more than one anchor. If you use only one anchor, make sure your boat has enough space to swing full circle in case of shifting winds.
- Keep the anchor and line in an area where it will be readily available in an emergency.

Dropping Anchor

1. Have a crew member carefully lower the anchor, keeping a slight tension on the line as the anchor drops. Maintain tension after the anchor reaches the bottom. Simply throwing the anchor overboard usually fouls the line and requires starting over.
2. Maneuver the boat slowly aft until the proper length of line is run out.
3. Fasten the anchor line around a deck cleat. Anchor flukes should dig into the bottom and hold boat in position.
4. Check shoreline landmarks when you drop anchor. Check the position of the landmarks again 30 minutes later. If your boat's position has changed, the anchor is dragging and must be reset.

Weighing Anchor

Weighing, or pulling in the anchor, requires moving the boat towards the anchor and pulling in the anchor line as the boat moves. When the line is vertical, pull up firmly on the anchor line to free the flukes from the bottom. If the anchor remains stuck, feed out a few feet of line and attach it to the bow cleat. Maneuver the boat around the anchor, keeping the line taut until you find an angle that will pull the anchor free. Remove all aquatic plants and dirt from the anchor before putting it in the boat.

DOCKING

Always approach the dock slowly. If possible, come in against the wind or current, whichever is stronger. Come in at a 30-45° angle. As the boat nears the dock, slowly swing parallel to it. If wind or current is moving toward the dock, move parallel to the dock further out. Let the wind or current push you in. Use extreme caution if wind or current is from your stern. Approach slowly at a slight angle with engine in slow reverse. Gently swing parallel. Tie stern first, then the bow.

If the weather looks bad, use spring-lines from the bow and stern to dock amidships of the boat. Tie up on the downwind side of the dock. If the wind is changeable, place fenders over the side between the boat and the dock. Bow eyes, stern eyes, or midship eyes should be used when tying off your boat. Do not use ski tow bar, ski pylons, rails, or fender clips to tie off your boat.

MOORING

After you have positioned your boat next to the dock, you must secure it with mooring lines to keep it in position. Mooring lines must be long enough to secure your boat wherever it may be docked. For example, the length of the lines for a 20-foot (6.1 m) pontoon should be at least 19 feet (5.8 m). An eye splice at the end of each line works well with bow or stern cleats.

The mooring lines used most often are the bow line, the stern line, and spring lines (Figure 5-4). Each line has a specific purpose. The bow line and the stern line secure your boat's bow and stern. The two spring lines keep your boat from moving forward or backward when you are moored alongside a dock.

If you are mooring your boat for a short time, bow and stern lines may be the only lines you need. If you are mooring your boat for a

longer time or the currents are swift, you should use spring lines. The stern spring line leads from the boat's stern cleat forward to the piling or cleat on the dock. The bow spring line leads from the bow cleat aft to the dock. Do not moor your boat using the ski eye or ski pylon.

If you are mooring your boat in a slip, bow and spring lines, port and starboard, will keep your boat in position.

NOTE: If tides are a consideration, be sure to leave slack in the lines to make up for the rise and fall of the water while your boat is docked.

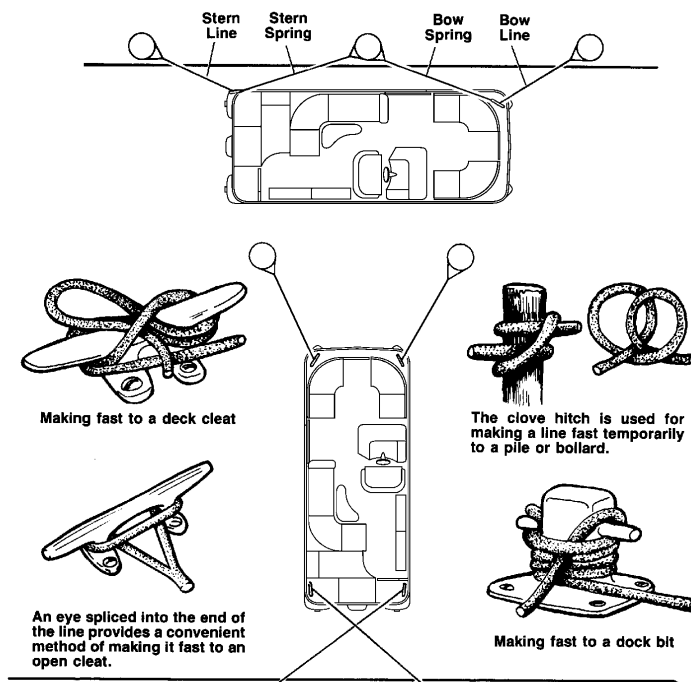

FIGURE 5-4 MOORING

EMERGENCY OPERATION

Boaters should respond to emergency calls if they are nearby and can help. You are expected to proceed to the scene and render assistance. Distress calls often are made for assistance with a disabled boat. A VHF marine radio (channel 16) is the best device for calling for help. Two international emergency signals are MAYDAY (life/death situation, request immediate assistance) and PAN PAN (safety of the boat or person in jeopardy).

The Federal Boat Safety Act of 1971 requires boat operators involved in accidents to offer aid to others in the accident and in emergencies. The law's "Good Samaritan" clause also absolves you from civil liability in the event that your assistance causes bodily injury or property damage.

As a boat owner, you have accepted many responsibilities. You should know how to cope with any type of emergency that could occur on your boat or someone else's. There is a way to handle each emergency – if you do not panic! Proceed calmly using good common sense. Some tips for particular situations are listed below.

Fire or Explosion

If a fire occurs, stop the boat immediately. Position the boat so that the fire is downwind. Boat fires involving flammable liquids, such as gasoline, can be extinguished with your dry chemical or carbon dioxide type extinguisher. Read the extinguisher directions and memorize them. Be prepared to use the extinguisher quickly if the need arises.

You must decide quickly whether to abandon ship or stay aboard and try to extinguish it. If the fire involves a trash container, smoldering upholstery or an electrical fire, try to extinguish the blaze by aiming the extinguisher nozzle at the base of the flame. However, a fire involving the fuel system greatly increases the danger of an explosion. If it is necessary to abandon ship, make sure all passengers wear a PFD or take it with them before going overboard.

Fire is an immediate danger after a gasoline vapor explosion. Gasoline floats on water and can spread out over the surface of the water. If you do abandon ship, keep yourself and your passengers clear of the burning boat.

Storms

Storms sometimes appear without advance notice. Although weather information from meteorological observation and reporting stations is available, weather bureau predictions can be wrong or information gathering equipment can fail. Many marinas fly weather signals. You should learn to recognize these signals and monitor your local weather forecasts before leaving port. Watch the horizon for indications of an approaching storm.

The present and forecasted weather conditions are of primary consideration, but a threat of possible storms should always be a concern. There is no substitute for a strong understanding of what action to take when the weather takes a turn for the worst. Return to a safe port if time allows. If it is impossible to do so, stow or tie down all loose gear and instruct everyone aboard to put on a PFD.

Fog

When warm air is above cooler water, its temperature drops. As the air cools, it loses its ability to hold moisture, and fog develops when the air temperature drops to the dew point temperature. Dew point temperature depends on the amount of humidity in the air. You should be aware that fog can form quickly as the air temperature drops, especially if the air is calm and humid.

Remember the following guidelines:

- Turn on running lights.
- Instruct everyone onboard to put on a PFD.
- If your boat has depth finding equipment, take soundings and match them with soundings on your charts.
- Station a person forward on the boat as a lookout.
- Reduce your speed. From time to time, stop the engine and listen for fog signals.

- Sound the horn at proper intervals to warn other boaters.
- If there is any doubt in continuing boat movement, anchor. Listen for other fog signals while continuing to sound the fog horn for a boat at anchor.

Man Overboard

If someone in your boat falls overboard, turn the steering wheel to move the propeller away from the person. Circle around quickly, approaching into the wind and waves. Turn off the engine when the person is alongside. If he/she is able to grasp, throw him/her a line or extend a paddle or a boat hook within his/her reach. Help the person back on board.

Do not dive over the side after an unconscious person or non-swimmer unless you are trained in lifesaving techniques. It is harder to save two people than one. If the victim has sunk out of sight, probe gently beneath the surface with a paddle or boat hook. Do not restart the engine until you have drifted clear of the victim's suspected location.

Collision

If you are involved in a collision with a boat, or with a fixed object such as a pier, sandbar, reef or bridge, check for injuries and render first aid if necessary. Before proceeding, check out your boat thoroughly. Check steering cables for possible jamming. Raise the motor and inspect for possible propeller or lower unit damage. Proceed carefully to port and remove the boat from the water to thoroughly inspect it for damage.

Running Aground

Operating in shallow water can present a number of hazards. Sand bars in narrow inlets are constantly shifting, making it difficult to mark them with buoys. Sometimes, sand bars are indicated by waves as they form into breakers when passing over sand bars.

If your boat runs aground, first check persons aboard for injury, then check for damage to the boat. It may be possible to rock the boat by shifting the weight of the passengers and gear and by raising the drive unit while reversing the engine. If you ground your boat on a sand bar, shut down the engine and seek help from another boater or radio for help. See your dealer as soon as possible, as sand ingested in the engine cooling system can cause major engine damage.

If the drive unit strikes an underwater hazard, check for boat and drive unit damage. Tubes still float if they are punctured. Go at a slower speed. A water-logged tube may change handling characteristics. If the engine vibrates excessively after striking an underwater obstruction, it may indicate a damaged propeller. If vibration is noticeable, return to port slowly to prevent further drive and engine damage from an out-of-balance condition. Watch the temperature gauge to make sure the engine does not overheat.

Towing and Being Towed

If wind and waves are high, it may not be easy to extend the tow line from one boat to another without risking a collision. Use a light throwing line with a weight on one end and the heavier towing line secured to it. Do not tow other boats with the ski tow bar.

ACCIDENT REPORTING

NOTE: The operator of a vessel that is being used for recreational purposes is required to file a report immediately to the reporting authority in the state where the accident occurred whenever an accident results in: loss of life or disappearance of a person; an injury which requires medical treatment beyond first aid; property damage of \$2,000 or more; or complete loss of the vessel. State authorities may require reports of property damage less than \$2,000. The owner of the vessel shall file the report if the operator cannot.

The form can be obtained by contacting the U.S. Coast Guard information line at 1-800-368-5647.

A rectangular box containing a black triangle with a white exclamation mark inside, followed by the word "CAUTION" in bold, uppercase letters.

To prevent boat damage, DO NOT use deck hardware for towing.
Use a commercial towing service.

6 CARING FOR YOUR BOAT

Proper care helps ensure that your boat will continue to look like new after years of service. We recommend that maintenance and repairs be performed by your dealer, however, some owners may prefer to take care of routine maintenance and repairs themselves. For those individuals, this chapter includes general information and basic procedures.

When your boat is not in use, protect it from the elements by storing it inside, under a roof, with a mooring cover or playpen cover over it, or with furniture covers installed. Do not store your boat outside. Do not dock the boat under trees, as dirt, leaves and other debris will accumulate on the floor and vinyl surfaces. This may cause stains or mold.

IMPORTANT: Check with your dealer before beginning any maintenance or repair if you are not sure about the proper tools, equipment and supplies to be used. Wash your boat and tubes after each use. Check with your local dealer for proper care and maintenance if using in salt or brackish waters.

NOTE: Always refer to the manufacturers' manuals for detailed maintenance and repair procedures. If information in this manual conflicts with information in the manufacturer's manuals, the manufacturers' manuals must take precedence.

ENGINE

Refer to the engine Owner's Manual for recommended frequencies and detailed information about engine care, maintenance and recommended fuels. If you have operated the boat in shallow or salt water, flush the engine with fresh water at the end of your boating excursion.

ALUMINUM SURFACES

Cleaning

Treat natural aluminum portions of aluminum boats with a clear protective coating to reduce natural oxidation. Rinse occasionally with clear water or mild detergent to keep these portions of the boat clean. Use water and mild detergent for cleaning and protect the surface with a liquid cleaner or wax. Do not use harsh chemicals or abrasives.

Remove stains or light corrosion with a good metal polish. Buff with a fine rubbing compound only if necessary. Remove algae, scum, or other marine growth while they are still wet. They are much harder to remove if they have had a chance to dry out.

Painting

Some anti-fouling paints react adversely with aluminum. Do not use paints containing copper, mercury or lead on aluminum boats with or without primer. Anti-fouling paint may be used if you do not run your boat in salt water. Ask your dealer to recommend the right paint for your situation.

Corrosion/Electrolysis

Modern boat building techniques minimize corrosion problems on aluminum models; nevertheless, corrosion can occur when dissimilar metals come in contact and are wetted by contaminated water. In general, saltier water leads to faster corrosion. To minimize this problem, use a gasket when mounting non-aluminum fixtures or hardware to aluminum. Never use an aluminum boat as the ground wire for an electrical circuit. Electrical equipment should be completely insulated from the vessel to eliminate electrolysis and corrosion.

NOTE: There is danger of an electric current in the water near boats linked to shore power.

Sacrificial anodes are required for saltwater and help reduce the chances of damage to your boat. Call your dealer with questions.

IMPORTANT: Do not attach copper, steel, brass or bronze directly to the aluminum on your pontoon. Doing so may cause an electrolytic reaction. Use only aluminum or stainless steel or separate dissimilar metals with a gasket.

PLASTIC COMPONENT MAINTENANCE

Keep the dull and shiny plastic surfaces clean to prevent dust and dirt from forming an unattractive film.

Clean the dull and rough plastic surfaces with warm soapy water and a scrub brush. Be sure to use mild soap, a dish liquid or equivalent, and a soft bristled brush. Do not at any time use an abrasive detergent/vehicle cleaner or a wire bristled brush. The plastic can become permanently scratched. Cleaning the shiny and smooth plastic components requires different care. Use a spray bottle glass cleaner and soft cotton cloth or sponge. Having a soft cloth/sponge is vital to cleaning. Also, make sure the cleaner used is specified as a glass treatment. If these specific products are not used, serious damage to the plastic may result. For maximum shine, polish the smooth plastic surfaces in a light circular motion.

TUBES

If a rock, log or other obstacle punctures a tube, it will not fill completely with water. If water enters a portion of the tube, the boat will list, but it will not sink. Repairing a punctured tube requires specialized welding skills. Contact your dealer for tube repairs.

The tubes of your boat may be coated with a clear material designed to lengthen the time your boat looks new. This coating is not designed to last more than part of a season. If you would like to clean or repair your tubes, please see your dealer for help.

SALTWATER USE

If your boat is in contact with saltwater, remove it from the water after each use and flush it from top to bottom, inside and out with fresh water. Clean hardware and spray with a marine corrosion inhibitor every week or even more often. Saltwater can also affect the engine. Contact your dealer or Premier Marine for additional information about using your boat in saltwater.

CAUTION

DO NOT store boats on carpeted bunks or any other type of surface that can hold salt or any other chemicals near or on the surface of the boat. These surfaces WILL corrode and damage the boat.

Sacrificial Anodes are **required** for saltwater and help reduce the chances of damage to your boat. Call your dealer with questions. The care and maintenance of your boat is extremely critical in saltwater areas. Most materials can be negatively impacted by both direct contact while in the saltwater as well as being on a lift over saltwater.

DECK HARDWARE AND FITTINGS

Clean all cleats, rails, and similar equipment periodically with good chrome cleaner and polish with paste wax to prevent corrosion. Replace broken or damaged hardware by bolting it through the deck while using a reinforcing block underneath.

Use deck hardware only for its intended purpose. Do not use stanchions for tying off fenders, mooring lines, or water ski ropes. A mooring cleat should not be used for a water ski rope if obstructions prevent it from swinging in a proper arc.

Sunlight and ozone eventually cause a loss of elasticity in rubber components. Inspect them frequently and replace them when signs of hardening or surface cracking are detected.

SEAT COVERINGS AND VINYL

The vinyl used on your boat requires routine care. Keep the vinyl clean and dry to keep mildew from forming. Open the seat cushions and wipe them dry after each use. In very rainy weather, cover, open or remove cushions since seams can trap and absorb moisture. If you remove the cushions, store them in a dry, well-ventilated place. Keep the boat covered when not in use to prevent aging of the upholstery.

Each week, wipe all vinyl surfaces with a soft damp cloth and towel dry. For dirt and stains that cannot be removed with a damp cloth, clean with a mild soap and water solution and, if necessary, a soft bristle brush. Rinse thoroughly and towel dry.

Suntan lotion and insect repellents can stain vinyl quickly and cause vinyl surfaces to deteriorate. Remove these products immediately after contact and wash the area with a mild soap solution. Rinse and towel dry.

If you have Ultrafabric materials on your pontoon, please wipe up spills as soon as they occur. Clean with soap and water. Thoroughly rinse all solution residue with clean water and air dry. A variety of clothing and accessories may contain dyes that could transfer to lighter colors, depending upon variations in temperature and humidity. Dye transfer is difficult to control, not always fully preventable, and may be irreversible.

IMPORTANT: Harsh detergents, abrasives, bleach and solvents can cause permanent damage to vinyl upholstery. Refer to the manufacturer's website for recommended stain removal procedures located in your packet.

CANVAS AND BOAT COVER

The canvas and boat cover are composed of a coated heavy-duty polyester fabric. They resist mildew, rot and the weather. ("Canvas" in this section refers to the various enclosures available, Bimini tops and boat covers.) If canvas is wet, let it air dry before you store it. Never store canvas damp or wet. Provide proper ventilation to limit the possibility of mildew.

Canvas covers are not watertight; they may drip at seams. Seam sealer designed for canvas is recommended for sealing the cover. Keep the canvas clean. Dirt and dust on canvas support the formation of mildew. To clean the canvas, wet down all of the canvas material. Scrub it with a soft bristle brush and a solution of mild soap and water. Rinse thoroughly with fresh water to remove soap residue. Never use detergent or bleach on your canvas. Brush or sweep the underside of the top. Spray with disinfectant to prevent mildew. Lubricate zippers with paraffin and snaps with petroleum jelly.

Clean the plastic windows by flushing them with clear water. After the dirt is removed, use an appropriate window cleaner. Do not wipe dirt from dry plastics or use abrasives. The plastic can become permanently scratched or dulled.

FLOOR COVERINGS

Keep boat covered when not in use to prevent exposure to excessive environmental conditions and direct sunlight. Brush off or vacuum loose dirt regularly. Clean flooring with mild soap and warm water. Apply with a soft bristle scrub brush. Rinse thoroughly with a hose to remove all soap residue and let air dry. Do not use a pressure or power washer on your pontoon in any instance.

Do not use acetone, citrus-based cleaners, industrial-strength cleaners, powder abrasives, or Pine-Sol. Use of these cleaners or use of a power wash can void the warranty. Refer to manufacturer's website for additional information.

FIBERGLASS AND COMPOSITES

The console and certain optional equipment such as galleys, motor covers, raised platforms, and rod lockers may be made of fiberglass or composite materials. Use caution while repairing or cleaning these products. You can scratch or melt these surfaces beyond repair.

Keep these surfaces clean to prevent dirt from scratching and dulling the finish. Clean them with a mild detergent and water. Do not use abrasives! At least twice a year, apply a coat of wax after cleaning and buff with a soft cloth to bring back the original sheen. If the fiberglass surface has oxidized (appearing as a light white milky film), you may want to use a rubbing compound before waxing. Your dealer can recommend a good commercial product to use.

TUBE MAINTENANCE

Use a commercial hull cleaner and a brush to remove algae or scum on the tubes. They are easier to remove if they are not allowed to dry out. If your boat will remain in the water, check with your dealer about the best method for preventing algae or scum buildup that is common in your area.

7 WINTERIZATION AND STORAGE

This chapter includes general information for winterizing and storing your boat after the boating season. Your dealer can advise you about preparing your boat for storage. Following the procedures in this section helps extend the life of your boat and its equipment and simplifies fitting out after storage.

Ventilation is very important during storage. Indoor storage is ideal, especially in areas where ice and snow accumulate. Ratchet covers are not designed for snow loads. Snow build up can cause the canvas to stretch and will not return to the original size/condition. Make sure the storage building has adequate ventilation. If you use outdoor storage facilities, have your boat shrink wrapped by a dealer or cover your boat with a canvas cover. Provide ventilation to keep the boat from “sweating” by building a frame over the boat to support the canvas. Build the frame several inches wider than the boat so the canvas will clear the rails.

Before preparing your boat for winter storage, thoroughly check the condition of the boat, its systems and equipment. Note any repairs needed. The need for repairs may become apparent during winterization. Make arrangements to have the repairs completed.

PREPARATION FOR STORAGE

Preparing your boat for winter storage is similar to the routine exterior care. Refer to Chapter 6 for specific cleaning solutions and procedures.

Lifting Your Boat

The best way to lift your boat out of the water is to load it on your trailer (see Chapter 4 for instructions). If a trailer is not available, arrange to have a marina lift your boat out of the water. Workers at the marina know the proper way to lift your boat as noted below and have the proper equipment available. See your dealer if you have questions about lifting your boat.

Please use caution when lifting your boat. Never lift the boat any higher than is absolutely necessary to clear the transport trailer. Never reach under or stand under a lifted boat. Always support the tubes properly and level when storing. The bow and stern eyes are designed for lifting all boats except the Escalante from the four points following these guidelines:

- In the front of the boat use a soft wrap between the strap and the front gunnel to prevent scratching the surface during lifting.
- The boat must be lifted from all 4 points, 2 in the front and 2 on the rear of the boat.
- The front and rear of the boat require a spreader bar to keep the straps vertical within +/-10 degrees of the tow eyes.

Tubes

Scrape off any crusted marine growth and barnacles, then scrub thoroughly to remove marine growth and scum. Check for dents, water in the tubes and cracks. Make any necessary repairs.

Deck

Wash the deck and walkway surfaces. Clean the marine grade flooring. Clean all deck hardware with good stainless or chrome cleaner, then apply one coat of rust inhibitor. Corrosion inhibitors are available from your dealer.

Remove all cushions and any other items that can hold moisture and cause mildew. Cushions may be left on board only if they can be propped open where air can circulate. If you leave life jackets and other safety equipment on board, be sure to leave space around them for adequate air circulation.

Engine

Refer to the engine manufacturer’s manual for detailed information about preparing the outboard or I/O engine for winter storage. It is recommended that a fuel stabilizer be added to the gas in the tank.

Batteries

Remove the batteries and store them in a location away from freezing temperatures. Batteries should be stored in a cool, dry place on a wooden pallet. Do not place batteries directly on concrete, brick, or dirt floors because the charge will be absorbed into the ground. Charge the batteries once a month or apply a continuous trickle charge while they are being stored.

WARNING

Battery electrolyte can cause severe eye damage and burn your skin. Wear goggles, rubber gloves and a protective apron when working with a battery. If the electrolyte spills, wash the area with a solution of baking soda and water.

Clean the outside of the battery case, terminals and battery clamps with a baking soda and water solution. Do not allow the solution to enter the battery cells.

Clean battery posts and clamps with a piece of fine grit emery cloth. Use a light sanding motion when cleaning. Apply a light coat of petroleum jelly to cover the ends of the battery cables.

Freshwater System

Remove water tank and drain. Make sure water supply hoses from the tank are drained.

Livewell

Remove the standpipe tube and allow all water to drain from the livewells. Run the livewell pump just long enough to ensure that all water is removed. Remove the livewell inlet hose and drain.

SUPPORTING YOUR BOAT DURING STORAGE

Your boat's trailer is the ideal support during storage or whenever it is not in the water because it supports the boat under the main frames. Loosen or remove all tie downs. Place blocks under the axles to keep tires away from the ground.

If your boat is not stored on the trailer, see your Authorized Premier Dealer for proper storage procedures.

If you are storing your boat on a lift, make sure it is supported properly on the bulkheads of the tubes. A bunk type support should support the entire length of the tubes. A folding lift type should support the entire length of the deck.

Always store your boat with the bow higher than the stern to prevent possible damage by way of water freezing in the nose cone areas.

IMPORTANT: Improper storage of your boat can cause boat damage that is not covered by the warranty.

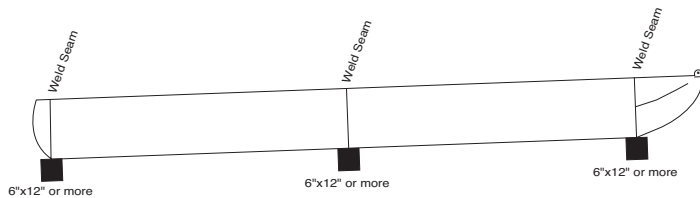

RECOMMISSIONING AFTER STORAGE

Fitting out is not difficult if the boat was properly prepared for storage. Before launching your boat, do not load unneeded equipment or personal items until the launch and final checkout are complete. For detailed information on recommissioning your boat's systems and equipment, refer to the Owner's Manual for each system or component.

1. Inspect, visually and by smelling, the fuel system and all associated components for proper connections, wear, leaks or other damage and needed repair. Inspection of the fuel system is a most important safety precaution.
2. Check propellers for proper installation and tightness. Clean the propeller if necessary.
3. Inspect all life jackets, anchor lines and other safety equipment for proper operation and physical condition. Repair or replace if necessary.
4. Check all safety equipment including flares, flags, fire extinguishers, and first aid kits. Replace equipment as necessary.
5. Check the charge on your battery. Recharge or replace it if necessary.
6. Clean battery terminal posts and cable terminal with a wire brush or bronze wool. Inspect all battery wiring. Repair or replace if necessary.
7. Install the batteries and attach the cables. After cable posts are tightened down, smear posts with petroleum jelly or marine grade grease to keep out air and acid. Check all wiring connections and contacts for corrosion and tightness.
8. Inspect all wiring for fraying, wear, loose connections or other damage. Repair or replace if necessary.
9. Inspect all switches, controls and other related equipment for proper operation. Repair or replace if necessary.
10. Test the operation of the navigational lights and other lighting on board. Repair or replace as necessary.
11. Reinstall the drain plug after coating the threads with Teflon[®] tape. Some models have expandable rubber drain plugs. Be sure they are tight.
12. Check all steering controls, cables and linkage for free operation.
13. Test run the engine as directed in the equipment manuals.
14. Check that water intake for the livewell pump is clear.

8 HELPFUL INFORMATION

BOATING REGULATIONS

The local Sheriff Marine Patrol, local Coast Guard office, or state Department of Natural Resources is responsible for enforcing boating regulations. Their goal is to help the boating public. You are subject to marine traffic laws and the "Rules of the Road" for both federal and state waterways; you must stop if signaled to do so by enforcement officers and permit to be boarded if asked. The "Rules of the Road" can be obtained from your local U.S. Coast Guard Unit or the U.S. Coast Guard Headquarters by calling 202-512-1800 or faxing your request to 202-512-2250 and asking for the publication titled "Navigational Rules, International-Inland." For additional information visit www.uscg.mil.

Many pamphlets prepared by the Coast Guard are available. They explain signal lights, buoys, safety, international and inland regulations, and other information which goes beyond the scope of this manual. "Aids to Navigation" (U.S. Coast Guard pamphlet #123) explains the significance of various lights and buoys. Because of proposed alterations in buoys and markers, contact the U.S. Coast Guard to stay informed of changes. Other pamphlets, including the "Boating Safety Training Manual" and "Federal Requirements For Recreational Boats," are also available from the U.S. Coast Guard Headquarters.

The spoken word "MAYDAY" is the international signal for distress. MAYDAY should NEVER be used unless there is grave or imminent danger, and you are in need of immediate assistance.

RULES OF SEAMANSHIP

Right-of-Way

In general, boats with less maneuverability have right-of-way over more agile craft. You must stay out of the way of the following vessels:

- A vessel not under command or aground. Due to their circumstances, these vessels have no maneuverability.
- A vessel restricted in its maneuverability. These vessels are performing work which limits their maneuverability such as: surveying, dredging, laying pipe or cable, or servicing navigational markers among others.
- A vessel engaged in fishing. These include boats fishing with lines, trawls or nets, but not trolling lines.
- Sailboats. Sailboats have the right-of-way over power boats; however, if a sailboat is using a propeller to move forward, it is considered a power boat even if its sails are up.

Meeting Head-On

When two boats meet head-on, neither boat has the right-of-way. Both boats should decrease speed and pass port to port, however, if both boats are on the left side of a channel, each vessel should sound two short horn blasts and pass starboard to starboard. See Figure 8-1.

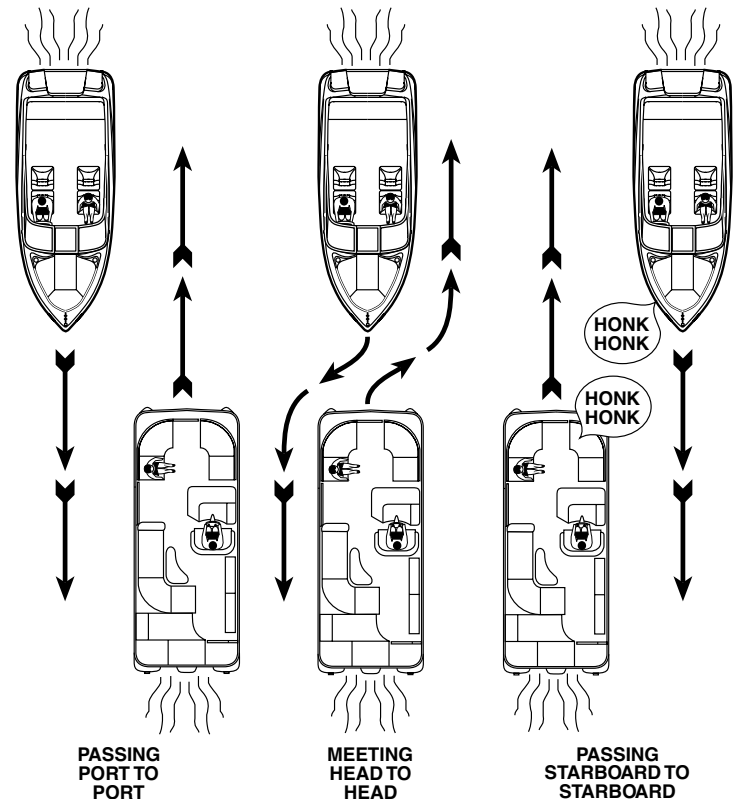

FIGURE 8-1 MEETING HEAD-ON

Crossing Situations

In a crossing situation, the boat on the right from the 12 to 4 o'clock position has the right-of-way. It must hold course and speed. The boat without right-of-way must keep clear and pass to the stern. See Figure 8-2.

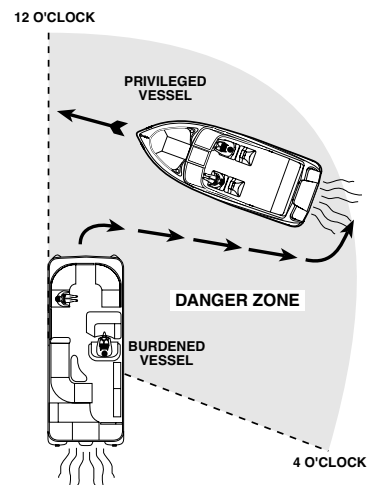

FIGURE 8-2 CROSSING

Overtaking

The boat overtaking the one ahead must yield the right-of-way to the boat being passed. The overtaking boat must make any necessary adjustments to keep out of its path. The boat being passed should hold its course and speed. See Figure 8-3.

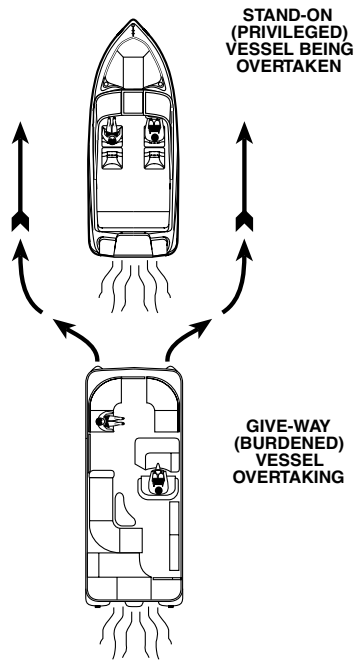

FIGURE 8-3 OVERTAKING

The General Prudential Rule

The General Prudential Rule regarding right-of-way is that if a collision appears unavoidable, neither boat has right-of-way. As prescribed in the “Rules of the Road,” both boats must act to avoid collision.

Night Running

Boats operating between sunset and sunrise (hours vary by state), or in conditions of reduced visibility, must use navigational lights. Nighttime operation, especially during bad weather or fog, can be dangerous. All “Rules of the Road” apply at night, but it is best to slow down and stay clear of all boats regardless of who has right-of-way.

To see more easily at night, avoid bright lights when possible. Also, it is helpful to have a passenger keep watch for other boats, water hazards and navigational aids.

To determine the size, speed and direction of other vessels at night, you should use the running lights. A green light indicates the starboard side, and a red light indicates the port side. Generally, if you see a green light, you have the right-of-way; if you see a red light, give way to the other vessel. See Figure 8-4.

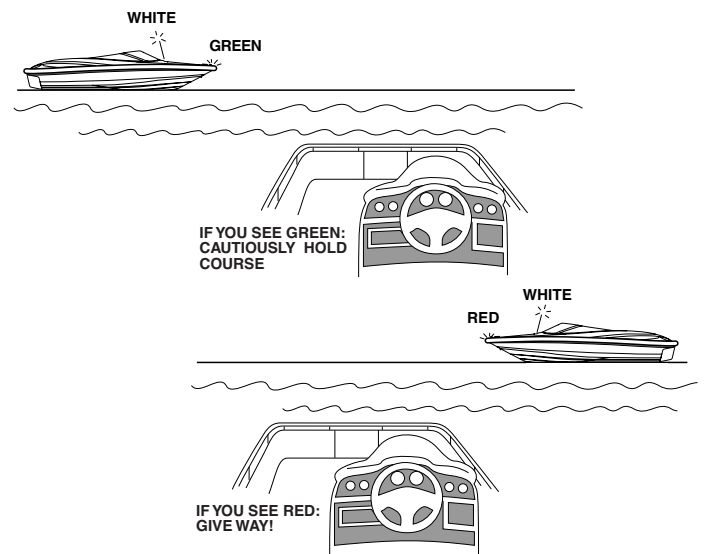

FIGURE 8-4 NIGHT RUNNING

Whistle Signals

Out on the water, whistle signals are commonly used. Although using a whistle signal is not necessary every time a boat is nearby, operators must signal their intentions, when necessary, to avoid potentially confusing or hazardous situations. Use whistle blasts early enough to be noticed and understood by other boaters.

It is customary for the privileged boat to signal first and the give way boat to return the same signal to acknowledge she understands and will comply.

Use the danger signal (five or more short and rapid blasts) if intent is not clear. A short blast is 1 or 2 seconds long. A long blast is 4 to 6 seconds long. The Navigational Aids Chart at the end of this chapter lists the meanings of the various whistle signals.

RECOMMENDED READING

We recommend that you read the boating literature published by your state boating agency and the U.S. Coast Guard. Other suggested reading includes the following:

United States Coast Guard Auxiliary. *Boating Skills and Seamanship*. LC74-164688. (illus.) (ISBN 0-930028-00-7). U.S. Coast Guard.

Bottomley, Tom. *Boatman's Handbook*. (illus.). 316 p. pap. (ISBN 0-688-03925-1, Hearst Marine Bk.) Morrow.

Chapman, Charles F. and Maloney, E.S. *Chapman's Piloting, Seamanship and Small Boat Handling*. (illus.) 62 p. (ISBN 0-87851-814-2, Pub. by Hearst Bks.); deluxe ed. (ISBN 0-87851-815-0). Morrow

CONTACTS

There are many good boating publications that have information about your area and what other boats are doing, such as clubs and other activities. Education programs are sponsored by publications and organizations such as the U.S. Power Squadron, U.S. Coast Guard Auxiliary, Canadian Coast Guard, American Red Cross, or see the country you are operating your boat in. See your dealer about special courses available in your area.

For detailed information, contact:

- American Red Cross
 - Local address (see local telephone directory)
- National Marine Manufacturers Association (NMMA)
 - www.nmma.org
- Boat U.S. Foundation for Boating Safety
 - www.boatus.com
- www.uscgboating.org
- U.S. Coast Guard Auxiliary
 - Local Flotilla or contact appropriate Coast Guard District
 - Headquarters www.cgaux.org
- U.S. Power Squadron
 - P.O. Box 30423, Raleigh, NC 27617
 - www.usps.com

NAVIGATIONAL AIDS

Aids to navigation (ATONS) help you to travel safely on the water. They help you get from one place to another and are most helpful if you have a nautical chart.

IMPORTANT: NEVER tie your vessel to an ATON. It is illegal because your boat blocks the ATON from the view of other boaters. Decreased visibility can contribute to a serious accident which may result in property damage, personal injury, or death.

Navigational Aids Chart

The illustrated Navigational Aids Chart located on the next two pages contains information concerning whistle signals, storm warnings, bridge signals, and buoy descriptions and information. It is your responsibility, as a safe boater, to be able to identify these navigational aids and to recognize their importance while learning about these aids to navigation and using this information while boating.

Regulatory markers are either signs or buoys. Signs are square with orange borders. Regulatory buoys are white and shaped like cylinders. They have horizontal orange bands near their tops and just above the water's surface. An orange circle on a marker means a controlled area. A message such as "No Wake, Idle Speed, No Skiing, or 5 MPH" may appear on the marker. An orange diamond means danger. If the diamond has an orange cross inside it, don't enter the area. The reason you should stay out, such as "Swim Area," may be printed in black on the marker.

A Special Sign

In Florida, you may see a special sign: "Caution, Manatee Area." When you see this sign, slow down to idle speed. Manatees, an endangered species, are passive, large, slow-moving mammals. Many manatees are seriously injured or killed each year by boat propellers.

NOTE: See inside back cover for Navigational Chart Aids and samples of buoys, signs, flags, etc.

9 BOATING TERMINOLOGY

Abaft	Toward the stern.
Abeam	Amidships, at a right angle to the keel.
Aboard	On, in or into a boat.
ABYC	American Boat and Yacht Council, Inc., the organization that sets voluntary safety and construction standards for small craft in the U.S.
Adrift	Without motive power and without anchor or mooring.
Afloat	On the water.
Aft	Describing the after section of a vessel or things to the rear of amidships and near the stern.
Aground	Touching bottom.
Amidships	In the center; the center portion of a vessel.
Anchor	A forging or casting shaped to grip the sea bottom and, by means of a cable or rope, hold a boat in a desired position.
Anchorage	A customary, suitable and (usually) designated harbor area in which vessels may anchor.
Astern	Toward the stern. An object that is aft of a boat is said to be astern of the boat.
Athwart	Across.
Aweigh	Off the bottom, said of an anchor.
Aye	Yes, while aboard a boat or ship. Means "I understand."
Bail (Bale)	To remove water from a boat by pump or bailer.
Ballast	Heavy material such as iron, lead or stone placed in the bottom of the vessel.
Beacon	A post or buoy placed over a shoal or bank to warn vessels. Also a signal mark on land.
Beam	Imaginary line amidships at right angles to keel of vessel. Also vessel's width amid-ships.
Bearing	The direction or point of the compass in which an object is seen.
Belay	To make fast to a cleat or belaying pin; to cancel an order.
Below	Beneath or under the deck. One goes below when going down into the cabin.
Bend	To fasten by means of a bend or knot.
Berth	A position, as a place to sleep or in which a vessel may be made fast; a margin of safety, as "a wide berth."
Bilge	The lower internal part of a boat's hull.

Bollard	A strong post for holding lines fast.
Bow	The forward part or front of the boat. An educational program that combines a variety of multimedia tools to promote water safety, boating education, environmental awareness, and careers within the marine industry.
Boater 101	
Breakers	Waves cresting as they reach shallow water, as at or on a beach.
Breakwater	A structure, usually stone or concrete, built to create a harbor or improve an existing one.
Bulkhead	Vertical partition in a boat.
Burdened Vessel	Former term for the vessel which must stay clear of vessels with the right-of-way.
Calking (Caulking)	Forcing filler material into the seams of the planks in a boat's deck or sides to make them watertight.
Camber	The arch of a deck sloping downward from the center toward the sides.
Capsize	To turn over. Required equipment on all motorboats except backfire flame outboards and diesels. Reduces chance of fire arrestor caused by backfires in internal combustion engines.
Carburetor	
Cardinal Points	The four main points of a compass; north, east, south and west.
Ceiling	The inside lining of the hull.
Certificate	Government paper, such as a boat's license.
Chart	A map of a body of water that contains piloting information.
Chine	The intersection of sides and bottom of a boat.
Cleat	A piece of wood or metal with projecting ends to which lines are made fast.
Clinker	A method of planking in which the lower edge of each strake overlaps the upper edge of the strake next below. (Also called lapstrake.)
Coaming	A raised edge, as around part or all of a cockpit, that prevents seawater from entering the boat.
Coast Guard	The federal marine law enforcement and rescue agency in the U.S.
Companionway	A hatch or entrance from deck to cabin.

Compass	A position, as a place to sleep or in which a vessel may be made fast; a margin of safety, as "a wide berth."
Cowls	Hooded openings used for ventilation.
Cradle	A frame used to support a vessel on land.
Current	The movement of the water in a horizontal direction.
Deadrise	The rise of the bottom of a midships frame from the keel to the bilge.
Deck	Any permanent covering over a compartment.
Deep-six	To discard or throw overboard.
Depth Sounder	An electronic depth-finding instrument measuring the time a sound wave takes to go from the vessel to the bottom and return, then displaying the result in feet, fathoms or meters.
Dinghy	A small, open boat.
Displacement Hull	Type of hull that plows through the water even when more power is added.
Dock	An enclosed or nearly enclosed water area; all the port installations; a place where vessels can moor, as a pier, wharf or floating dock.
Documented Vessel	Vessel registered with the U.S. Coast Guard.
Dolphin	A small group of piles in the water generally used for mooring or as a channel marker.
Draft	The depth of the vessel below the water line measured vertically to the lowest part of the hull.
Dunnage	Mats, boughs, pieces of wood or other loose materials placed under or among goods carried as cargo in the hold of a ship to keep them dry and to prevent their motion and chafing; cushioning or padding used in a shipping container to protect fragile articles against shock and breakage; baggage or personal effects.
Ebb	An outgoing tide.
Estuary	An inlet or arm of the sea.
Fathom	Six feet.
Fenders	Objects placed along the side of the boat to protect the hull from damage.
Flare	The outward spread of the boat's sides from the waterline to the rail at the bow. Also, a pyrotechnic signaling device that can indicate distress.
Fore	Used to distinguish the forward part of a boat or things forward of amidships. It is the opposite of aft or after.
Forward	Toward the bow.

Frame	Ribs of the hull extending from the keel to the highest continuous deck.
Freeboard	The vertical distance measured on a boat's side from the waterline to the gunwale.
Galley	The kitchen area of a boat.
Gimbals	Swivels used to keep equipment level.
Give-Way Vessel	The one which must stay clear of vessels which have the right-of-way.
Grab Rail	A convenient grip on a cabin top or along a companion ladder.
Gunwale	The upper edge of a boat's side. (Pronounced gunnel.)
Harbor	A safe anchorage protected from most storms; may be natural or man-made, with breakwaters and jetties; a place for docking and loading.
Hatch	An opening in a boat's deck for persons or cargo to go below.
Head	A marine toilet. Available with and without pump-out option.
Headway	Forward motion of a vessel through the water.
Helm	The wheel or tiller by which a ship is steered.
Holding Tank	Storage tank for sewage so that it will not be pumped overboard into the water.
Hull	The body of a boat.
Hypothermia	A physical condition where the body loses heat faster than it can produce it.
Inboard	More toward the center of a vessel; inside; a motor fitted inside the boat.
Inland Rules	Rules of the road that apply to vessel operation in harbors and certain rivers, lakes and inland waterways.
Intracoastal Waterways	(ICW) Bays, rivers and canals along the coasts (such as Atlantic and Gulf of Mexico coasts) connected so that vessels may travel without going into the open sea.
Jetty	A structure, usually masonry, projecting out from the shore; a jetty may protect a harbor entrance.
Keel	The permanently positioned fore and aft backbone member of a boat's hull.
Knot	To bend a line. Also, a unit of speed equal to one nautical mile (6,076.10 feet) an hour.
Launch	(1) To put a vessel into the water; (2) A small open powerboat mainly used for transportation between a vessel and shore.
Lee	The side opposite to that from which the wind blows.
Leeward	Situated on the side turned away from the wind. Opposite of windward.
Leeway	The amount a boat is carried sideways by the wind's force or current.

Limber Holes	Drainage holes in the bilge timbers of a vessel allowing water to run to a low point for pumping out.
List	(1) A continuous leaning to one side often caused by an imbalance in stowage or a leak into one compartment; (2) A light list is a printed listing of aids to navigation in geographical order or inclining of a vessel toward the side.
LOA	Length overall; the maximum length of a vessel's hull, excluding projecting spars or rudder.
Locker	A storage place, a closet.
Log	A record or diary of a vessel's journey.
Lubber's Line	A mark or permanent line on a compass that shows the course of the boat.
Making Way	Making progress through the water.
Marina	A place, essentially a dock area, where small recreational craft are kept; usually where floats or piers as well as service facilities are available.
MAYDAY	A radio distress call from the French "m'aidez" (help me); SOS in Morse Code.
Mooring	Commonly the anchor chain, buoy space, pennant, etc., by which a boat is permanently anchored in one location.
Motor	A source of mechanical power.
Motorboat	Any watercraft 65 feet or less in length propelled by machinery, whether or not such machinery is the principal source of propulsion.
Navigation	The art of conducting a ship from port to port.
Nautical Mile	6,076.12 feet, or 1,852 meters, an international standard; the geographical mile, the length of one minute of latitude at the equator, is 6,087.20 feet.
NMMA	(National Marine Manufacturers Association) NMMA is dedicated to creating, promoting, and protecting an environment where members can achieve financial success through excellence in manufacturing, in selling, and in servicing their customers.
NMMA Certified	National Marine Manufacturers Association Certification Program. An NMMA Certified boat is 5 times safer than a non-certified boat.
Nun Buoy	A conical, red buoy bearing an even number and marking the starboard side of a channel from seaward.
Oar	A long, wooden instrument with a flat blade at one end used for propelling a boat.
Outboard	(1) A propulsion unit for boats attached at the transom; includes motor, drive shaft and propeller; fuel tank and battery may be integral or installed separately in the boat; (2) Outside or away from a vessel's hull; opposite of inboard.

Outdrive	A propulsion system for boats with an inboard motor operating an exterior drive with drive shaft, gears and propeller; also called stern drive and inboard/outboard.
Overall Length	The extreme length of a vessel, excluding spars or rigging fittings. See LOA.
Painter	A rope attached to the bow of a boat for making it fast.
PFD	Personal Flotation Device.
Pier	A structure, usually wood or masonry, extending into the water used as a landing place for boats and ships.
Pile	A vertical wooden or concrete pole driven into the bottom; may be a support for a pier or floats; also used for mooring.
Piling	A structure of piles.
Pitch	(1) The up and down movement as the bow and stern rise and fall due to wave action; (2) The theoretical distance advanced by a propeller in one revolution.
Planing Hull	Type of hull that is shaped to lift out of the water at high speed and ride on the surface.
Port	The left side of a boat when you are facing the bow. Also a destination or harbor.
Privileged Vessel	Former term for the vessel with the right-of-way.
Propeller	Wheel or screw mechanism that pushes water aft to propel the boat.
RBFF	(Recreational Boating and Fishing Foundation) The RBFF is a nonprofit organization whose mission is to increase participation in recreational angling and boating and thereby increase public awareness and appreciation of the need for protecting, conserving, and restoring this nation's aquatic natural resources.
Rigging	The general term for all lines (ropes) of a vessel.
Roll	The sideward motion of a boat caused by wind or waves.
Rules of the Road	The nautical traffic rules for preventing collisions on the water.
Scope	The length of the anchor rope or chain. 6 to 1 scope means that the length of the anchor rope from the boat to the anchor is 6 times the depth of the water.
Scupper	A hole allowing water to run off the deck.
Sea Anchor	A floating canvas cone held open by wire rings with an opening in the smaller end and a rope bridle at the larger end attached to a line leading to the vessel; used in storm conditions to (a) keep the bow of the boat to the wind, and (b) slow downwind drift of the boat.
Seacock	A thru-hull valve; a shutoff on a plumbing or drainpipe between the vessel's interior and the sea.

Sirius™ Radio	Satellite radio system
Slip	(1) A berth for a boat between two piers or floats; (2) The percentage difference between the theoretical and the actual distance that a propeller advances when turning in water under load.
Sole	The cabin or cockpit floor.
Spar Buoy	A channel marker that looks like a tall, slender pole.
Stand-On Vessel	The vessel with the right-of-way.
Starboard	The right side of a boat when you are facing the bow.
Stern	The after end or back of the boat.
Stow	To store items neatly and securely.
Strake	Planks running fore and aft on the outside of a vessel.
Taffrail	The rail around a boat's stern.
Tide	The alternate rise and fall of waters caused by the gravitational attraction of moon or sun.
Topsides	(1) The sides of a vessel above the waterline; (2) On deck as opposed to below deck.
Transom	The transverse planking which forms the after end of a small, square-ended boat. (Outboard motors are usually attached to a transom.)
Trim	To arrange weights in a vessel in such a manner as to obtain desired draft at bow and stern.
Trimaran	Boat with three hulls—the center one is the largest.
Unbend	To cast off or untie.
Underway	Vessel in motion (i.e. when not moored, at anchor or aground).
USPS	U.S. Power Squadron, a private membership organization that specializes in boating education and good boating practices.
Ventilation	Ventilation occurs when air from the water's surface or exhaust gases from the exhaust outlet are drawn into the propeller blades. The normal water load is reduced and the propeller over-revs, losing much of its thrust. This continues until the propeller is slowed down enough to allow the bubbles to surface.
Vessel	Every kind of watercraft, other than a seaplane on the water, capable of being used as a means of transportation on water.
VHF Radio	A Very High Frequency electronic communications and direction-finding system.
Wake	Moving waves created by vessel motion. Track or path that a boat leaves behind it when moving across the water.

Wash	The loose or broken water left behind a vessel as it moves along; the surging action of waves.
Waterline	The intersection of a vessel's hull and the water's surface; the line separating the bottom paint and the topsides.
Water Works Wonders	Your single source of information on fishing, boating and caring for the water.
Way	Movement of a vessel through the water. Technically it is underway when not at anchor, aground or made fast to the shore. The common usage is interpreted as progress through the water. Headway when going forward, and stern way when it is going backward.
Well	Area at the rear of a boat where the motor may be located.
Wharf	A structure, parallel to the shore, for docking vessels.
Wheel	(1) The steering wheel; (2) The propeller.
Whistle Signal	A standard communication signal between boats to indicate change of course, danger or other situations.
Windward	Situated on the side closest to the wind. (Opposite of leeward.)
Yaw	To swing or steer off course as when running with a quartering sea.

PONTOON/DECK BOAT



- I understand that under Federal and/or State law it is a **crime** to operate a boat while persons are sitting on the front (bow), sides (gunwales), rear (stern), or swim platform. This behavior is considered grossly negligent operation of a boat.



- I understand that there is an awareness zone that includes the front (bow), sides (gunwales), rear (stern) and swim platform, and extends 30 feet behind and around this boat.

- I will educate all of my passengers on the awareness zone, and I will not allow anyone to enter the awareness zone unless the boat motor is turned off, the keys are removed, and I have counted to ten to allow the propeller time to stop spinning.



- I will take a head count to make sure all passengers are present and accounted for before starting the motor.

- I understand that it is particularly dangerous to sit on the front of the platform of this boat, because a slip between the pontoons will "funnel" a passenger into the boat propeller.



- I understand that the motor of this boat produces Carbon Monoxide, a colorless, odorless, and lethal gas that can quickly affect people in the awareness zone.

- I will not use any generator that is not supplied as part of the rental package on this boat.



- I understand that this boat has no brakes, so that stopping quickly may be difficult or impossible if I am going too fast.



- I will not operate this boat at speeds that are unsafe for the conditions.

- I will obey No Wake zones/signs.



- I have been instructed on how to use the navigation lights and anchor lights on this boat and I will display them properly if operating at night or when visibility is poor.

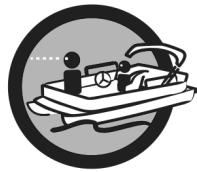

- I will make sure that there is a lookout other than the boat operator whenever passengers or parts of this boat obstruct the operator's view.



- I have been informed of the total capacity of ____ people and ____ lbs of gear for this boat. I will not exceed that limit.

- I understand that overloading this boat is unsafe and against the law.



- I will anchor where it is easy for other boats to see this boat (so long as the area is anchorable).

- I will anchor this boat only from the front (bow).



- I will check to make sure that the water is deep enough before allowing head-first diving from the boat.

- I will instruct my passengers **never** to dive or jump off of a moving boat.

- I will make sure that I, or someone who knows how to operate the boat, remain on board whenever the boat is unanchored.



- I have been instructed on what to do in the case of a person overboard, collision, or other dangerous situation.



- If this boat is equipped with an engine cut-off device, I will use it.

- I have received an operational orientation for this boat and understand that a written manual is on board.

NAVIGATIONAL AIDS CHART

REMEMBER THESE RULES

- OVERTAKING - PASSING:** Boat being passed has the right-of-way. **KEEP CLEAR.**
- MEETING HEAD ON:** Keep to the right.
- CROSSING:** Boat on right has the right-of-way. Slow down and permit boat to pass.

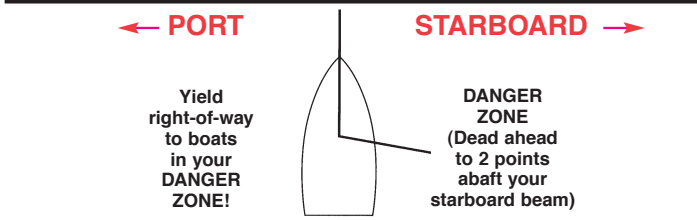

WHISTLE SIGNALS

- ONE LONG BLAST:** Warning signal (Coming out of slip)
- ONE SHORT BLAST:** Pass on my port side
- TWO SHORT BLASTS:** Pass on my starboard side
- THREE SHORT BLASTS:** Engine(s) in reverse
- FOUR OR MORE BLASTS:** Danger signal

BRIDGE SIGNALS

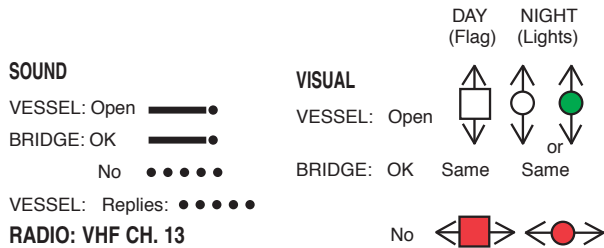

STORM WARNINGS

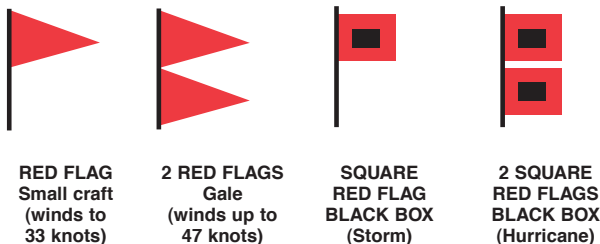

LATERAL AIDS AS SEEN ENTERING FROM SEAWARD

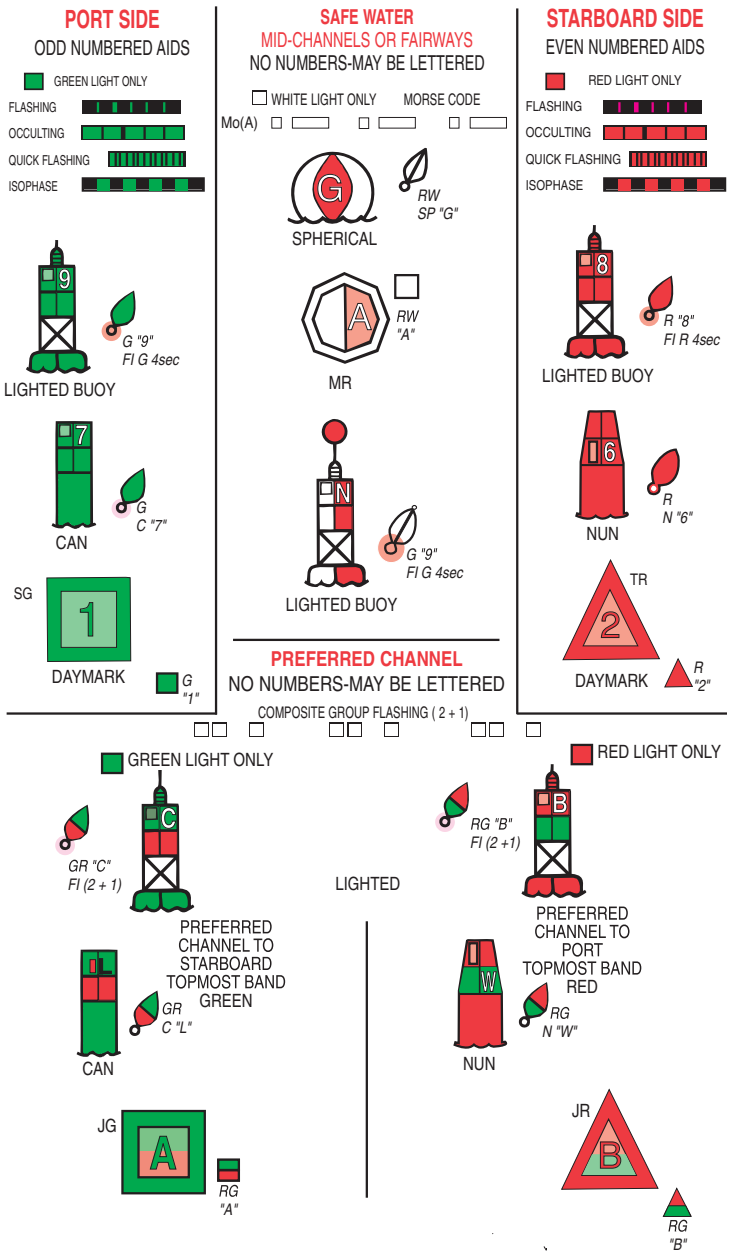



FOR MORE OWNER RESOURCES
visit www.pontoons.com/owners

Only the best boats on the water are fully certified for building and safety standards by the National Marine Manufacturers Association. Never purchase a boat unless you see the NMMA CERTIFIED sticker—just like the one on a Premier pontoon. NMMA certification means your pontoon is five times safer than a non-certified boat.

The following trademarks are the intellectual property of Premier Marine, LLC: Premier®, Premier: Go Beyond™, PTX®, Sunscape™, Sunsation™, Solaris™, Intrigue™, SuperSport™, Escalante™, SaltEx™, Ricochet®, including federally registered rights for trademarks identified with a ® symbol. Other trademarks are property of their respective owners.

Premier Marine promotes safe boating and recommends that a suitable boat operator be a licensed driver as well as the following: 1. Do not operate your pontoon under the influence of drugs or alcohol and always wear life jackets. 2. Do not operate unless all occupants are in designated NMMA seating positions. 3. Do not start the engines unless the driver's seat is locked in the forward-facing position. 4. For maximum enjoyment and safety, read the owner's manual and labels, and follow all safety checklists prior to the operation of your pontoon and motor. 5. Be certain the driver has the emergency kill switch lanyard attached at all times during operation. All specifications and options were accurate at time of printing and are subject to change without notice. Premier Marine shall not be held responsible for typographical errors. Boats may be shown with optional equipment. Consult your dealer to ensure availability of options and equipment that may no longer be available. ©2024 Premier Marine, LLC. All rights reserved.



O: 763.207.2800 | A: 1200 Minnesota Ave, Big Lake, MN 55309 | W: pontoons.com